

OES BEACON

Newsletter of the Oceanic Engineering Society



JUNE 2024, Volume 13, Number 2

www.ieeeoes.org

(USPS 025-095) ISSN 2164-8042



IEEE OES ADCOM MEETING
April 19–20, 2024 Singapore



The OES BEACON is published four times a year as a benefit to the membership of the IEEE Ocean Engineering Society. The OES Beacon is printed and distributed from IEEE headquarters in New York City, New York, USA.

Editor-in-Chief:

Harumi Sugimatsu—harumis@iis.u-tokyo.ac.jp

Co-Editor-in-Chief:

Robert L. Wernli—wernli@ieee.org

Associate Editors:

Masakazu Arima
Toshihiro Maki
Takumi Matsuda
Katsunori Mizuno
Takeshi Nakatani
Hisashi Shiba
Farley Shane
Blair Thornton

Contributing Editors:

Australia—Mal Heron
China—Lian Lian
Canada—James S. Collins
France—Philippe Courmontague
Germany—Christoph Waldmann
India—M. A. Atmanand
Japan—Hayato Kondo
England—Blair Thornton
Korea—Son Cheol Yu
Scotland—John Watson
Singapore—Venu Pallayil
Taiwan—Jenhwa Guo
USA—Stan Chamberlain

Publication Copy-Due schedule:

3rd Qtr: September 2024: August 14

4th Qtr: December 2024: November 14

Members are encouraged to submit copy highlighting 1) Chapter Events, 2) People & Company News, 3) Student & Young Professional News, 4) Technology Updates, or 5) other material of broad interest to the OES. Please send to Beacon Editor-in-Chief, Harumi Sugimatsu <harumis@iis.u-tokyo.ac.jp>. Word format, 1-1/2 space; Photos (always encouraged): jpg, 300 dpi preferred. Material becomes property of IEEE-OES. Please send e-mail or physical address corrections or updates to the EIC.

IEEE OCEANIC ENGINEERING SOCIETY EXECUTIVE COMMITTEE

President

BRANDY ARMSTRONG

Executive Vice President

MALCOLM (MAL) L. HERON

Vice President

Technical Activities
SHYAM MADHUSUDHANA

Vice President

Professional Activities
ELIZABETH L. CREED

Vice President

Workshops & Symposia
GERARDO ACOSTA

Vice President

OCEANS
VENUGOPALAN (VENU) PALLAYIL

Secretary

HARI VISHNU

Treasurer

BILL KIRKWOOD

Journal Editor-in Chief

KARL VON ELLENRIEDER

Past President

JERRY C. CARROLL

ELECTED ADMINISTRATIVE COMMITTEE

2022–2024

M. A. ATMANAND
JAMES S. COLLINS
BHARATH KALYAN
LIAN LIAN
HARUMI SUGIMATSU
ROSMIWATI MOHD MOKHTAR

2023–2025

ANDREAS MAROUCHOS
NIKOLA MISKOVIC
KAREN A. PANETTA
JOHN WATSON
ALBERT (SANDY) J. WILLIAMS 3RD
STEPHEN WOOD

2024–2026

MONIKA AGRAWAL
GABRIELE FERRI
MALCOLM (MAL) L. HERON
TOSHIHIRO MAKI
GIULIA DE MASI
KONSTANTINOS PELEKANAKIS

Front cover photos during OCEANS'09 Gulf Coast were taken by Stan Chamberlain, our previous OES photographer

IEEE OES Beacon Newsletter (ISSN 2164-8042) is published quarterly by the Oceanic Engineering Society of the Institute of Electrical and Electronics Engineers, Inc. Headquarters: 3 Park Avenue, 17th Floor, NY 10017-2394. \$1.00 per member per year (included in Society fee) for each member of the Oceanic Engineering Society. Printed in U.S.A. Periodicals postage paid at New York, NY and at additional mailing offices. Postmaster: Send address changes to IEEE OES Beacon Newsletter, IEEE, 445 Hoes Lane, Piscataway, NJ 08854
©2024 IEEE

Permission to copy without fee all or part of any material without a copyright notice is granted provided that the copies are not made or distributed for direct commercial advantage, and the title of the publication and its date appear on each copy. To copy material with a copyright notice requires specific permission. Please direct all inquiries or requests to IEEE Copyrights and Permissions Office.



IEEE prohibits discrimination, harassment, and bullying.
For more information, visit <http://www.ieee.org/web/aboutus/whatis/policies/p9-26.html>.

Table of Contents

<i>Ad Com Meeting Group Photo</i>	Cover
<i>Member Benefits—Did you know?</i>	3
<i>From the OES BEACON Editors</i>	4
<i>From the President</i>	5
<i>From Executive VP</i>	6
<i>VPWS Report</i>	6
<i>VP OCEANS Report</i>	7
<i>From the EIC's Desk</i>	8
<i>Request for Nomination for OES Awards 2024</i>	9
<i>IEEE YP Event in Lisbon</i>	10
<i>Chapters' Meeting in Singapore</i>	11
<i>Chapter News</i>	13
<i>Call for OES DLs 2025-2027</i>	15
<i>Decade of Ocean Science in the CWTM 2024 Workshop</i>	15
<i>Decade of Ocean Science in the SAUVC 2024</i>	16
<i>OES Contributions to the UN Ocean Decade Conference</i>	18
<i>Oceans 2024 Singapore Ocean Decade Initiative Panel</i>	19
<i>OES Conference Calendar</i>	21
<i>OTC Asia 2024 Report</i>	22
<i>OTC 2024 Report</i>	24
<i>CWTM 2024 Workshop Report</i>	25
<i>SAUVC 2024 Report</i>	27
<i>IEEE OES Summer School Report</i>	32
<i>SusTech 2024 Report</i>	34
<i>Ad on AUV2024</i>	36
<i>Ad on MIW24</i>	37
<i>Ad on UT25</i>	38
<i>Blast from the Past</i>	39
<i>OCEANS 2024 Singapore Report</i>	40
<i>Student Mixer at OCEANS 2024 Singapore</i>	45
<i>OES Member Reception at OCEANS 2024 Singapore</i>	45
<i>SPC Report</i>	46
<i>SPC Winner's Report—First Prize Winner Report</i>	53
<i>SPC Winner's Report—Second Prize Winner Report</i>	54
<i>Winning Poster Paper</i>	55
<i>Ad on OCEANS 2024 Halifax</i>	65
<i>Ad on OCEANS 2025 Brest</i>	66
<i>Who's Who in the IEEE OES</i>	68
<i>Election of OES AdCom Members</i>	69
<i>Welcome New and Reinstated Members</i>	70
<i>How to Receive Paper Copies of Each Beacon</i>	71
<i>OTC Asia 2024 Experiences</i>	71
<i>An Unprecedented Voyage on 'The Falkor (too)' Research Vessel</i>	73
<i>Berth of Opportunity</i>	76
<i>Attention OES Students</i>	78
<i>Back cover OCEANS 2024 Halifax</i>	Cover

Member Benefits—Did You Know?

Member Benefits

NEW!

There are as many specific approaches to leadership as there are leaders; but leading exceptional teams generally relies on three fundamental actions: building effective relationships, energizing your team, and delivering results.

Searching the title will take you to the IEEE site for the book.

<https://ieeepusa.org/product/leading-exceptional-teams/>

E-Book (PDF)

Member: FREE

Non-Member: \$2.99



Leading Exceptional Teams

Author: Dr. Dev Palmer

From the OES BEACON Editors

Harumi Sugimatsu and Robert Wernli

Well, OES has been busier than usual with several recent events. The biggest is the return to Singapore for the in person OCEANS conference and the many related meetings. We have many reports on the OCEANS 2024 Singapore in this issue. Surrounding this was the need to fill the president and Executive VP positions for the remainder of this year. Congratulations to Brandy Armstrong, our new president, and Mal Heron, our new Executive VP. Enjoy their articles in this issue.

Also included are articles from our Executive Committee that give the latest on OCEANS conferences, Workshops and Symposia activities and planning.

OES has had a vision to increase the number of student and young professionals (YPs) in the society. Based on the reports in this issue that vision is becoming a reality. Article highlights the OES YP-BOOST and their activities. OES also provides funding to get students to the OCEANS conferences via the Student Poster Competition (SPC) and other events for qualified applicants. This issue contains the SPC winning paper and comments from the participants.

Just prior to the Singapore OCEANS conference, the inaugural Oceanic Engineering Summer School was held. This pilot event drew in 43 eager participants. See the report in this issue. Next Summer School is planned to be held after the OCEANS 2025 Brest.

Again, on a larger scale, we have the reports on the OES support of the UN Decade of Ocean Science.

The AdCom election is again on the horizon. We have 14 members in the election for the 2025-2028 positions. They are listed in this issue. Election will open on 6 June 2024.

The planning is well on its way for the OCEANS 2024 Halifax conference upcoming in September. OTC Houston was just held in early May and there is a report in this issue on our participation as one of the OTC sponsors. Also included is a report on the very successful OTC Asia conference held from 27 Feb to 1 March.

Upcoming workshops and symposia are listed in the Conference Calendar and reported by our VP for Workshops and Symposia. Reports on SAUVC 24 (Singapore) and SusTech 2024 (Portland, Oregon) are included in this issue.

Our technology committees (TCs) continue to be more active as reported by our VP for Technical Activities. The CWTMA TC reports on their Marine Radar Wind and Wave Measurements for Short Term Forecasts webinar. The Journal



Harumi with OES friends at OCAENS 2024 Singapore (L to R: Chenxu Wang, Peng Ren, Harumi, Weimin Huang).



Singapore was a success, now, after 20 years, its time to set sail again for the OCEANS 2025 Brest conference.

EIC again provides a list of recently released papers that are available to our members.

Our chapters have been busy as the reports show. This issue contains the latest on the activities of the Japan and Malaysia chapters.

Have you done something exciting lately? Received an award or professional recognition? Be sure to contact your editors about submitting an article. And don't miss the Who's Who in OES article on one of our outstanding members in each issue. Want to participate as a technology speaker? See the Call for Distinguished Lecturer nominations in this issue.

There is a wealth of other information and articles in this issue that we hope you enjoy. And, as always, we'll close by inviting you to participate in your society. Submit articles and material for the Beacon. Or . . . volunteer for other society activities as a participant or an elected officer. It's your society and it is here to help you reach your professional goals. Enjoy.

Diversity in Leadership

Brandy Armstrong, President, president@ieeeoes.org

A First for IEEE OES

As the first female President of IEEE Oceanic Engineering Society (OES), I recognize the importance of this moment and that I have an opportunity to speak up. A diverse administrative committee brings new ideas and approaches to leadership, which I believe will serve our Society well if member volunteers are committed to working together to move the Society forward through change.

Diversity, Equity and Inclusion

Your President is a champion for Diversity, Equity, and Inclusion (DEI) in our community. **Diversity** is the presence of people of different backgrounds, perspectives, and identities in our community. **Equity** recognizes that we don't all start from the same place and must acknowledge and make adjustments to imbalances. **Inclusion** relies on Diversity and Equity and enables full participation of a diverse member base in the events happening at all levels of our community. Diversity and Equity are essential in fostering an inclusive Society, where community members feel they belong, which is a powerful catalyst to bring underprivileged and minority groups into Oceanic Engineering. These groups span gender, ethnicity, culture, socioeconomic status, sexual orientation and neurodiversity.

Diverse and inclusive Societies find and nurture the best talent, increase volunteer engagement, and see increased membership. IEEE Societies' experiences have shown that including DEI in strategic planning and leadership decisions results in integrity and technical excellence. How we interact with our fellow community members is at least as important to the purpose of the Society as technical skills.

We can build an ecosystem of Societies and collaborators who are also aware of and fostering an environment of Diversity and Inclusion. Our Berths of Opportunity program with Schmidt Ocean Institute (SOI) is one example of the type of program that we can create working with organizations who are strong supporters of DEI. IEEE OES has been a technical co-sponsor of the past two Ocean Sciences Meetings (OSM), another event where DEI is strongly emphasized. OSM held DEI events each day of the 6-day conference in February of 2024. The Oceanographic Society's *Oceanography* magazine published an entire Volume (Volume 36) on Building Diversity, Equity, and Inclusion in the Ocean Sciences, which they distributed for free at OSM as a conference co-sponsor. Exxon Mobil sponsored a half day program at OTC Asia on Diversity, Equity & Inclusion Insights. Breaking Barriers, Building Bridges: Harnessing the Power of Diversity in the Energy Industry.

OES's approach to DEI can position us for success and growth. IEEE recognizes this. The TAB DEI committee received unanimous approval at the February TAB meeting for a budget and additional committee members. The TAB DEI



MTS President Justin Manley (left) and OES President Brandy Armstrong present a plaque in appreciation of the Local Organizing Committee to the OCEANS Singapore Chair Venu Pallayil.

committee has already provided a toolkit to support all organizational units to manage initiatives toward advancing DEI, as well as embed DEI into ongoing activities. The first step is to establish a long-term DEI Committee within an organizational unit. The toolkit is available at <https://www.ieee.org/about/diversity-index/secure/volunteer-toolkit.html>

Leadership and their understanding of how to manage a diverse group of humans is the biggest determinant of the daily experience for our Society members. I encourage all IEEE OES members to contact your Administrative Committee and Executive Committee members to let them know your thoughts on Diversity, Equity, and Inclusion and how to better understand your needs as members.

As long as I am in OES leadership, I will continue to work to incorporate DEI in our purpose and culture and seek responsibility towards affective action. If you would like to get involved in advancing DEI efforts in IEEE OES please contact your President at president@ieeeoes.org.

Executive VP Report

Malcolm Heron, a New Executive VP



I was honoured by AdCom to be elected to the vacancy in the office of Executive Vice President for the remainder of the current term—to the end of 2024. The main duties of the ExecVP are to lead the Governance and Strategic Planning Committees, and to provide support to the President. These legalistic committees may sound a bit boring, but the reality is that without accurate documentation the

Society could easily lose its direction. In fact I think it will be

a challenge to get both of these documents onto the table before the end of the year.

My appointment comes after a long association with OES leadership as an ordinary member, then an elected member of AdCom, a couple of terms as VP for Technical Activities, and a general rouse-about for workshops and symposia. My real reason for my commitment to IEEE OES is to participate in the technical aspects of creating research activities and publishing results. This generates in me a strong desire to see OES flourish and provide opportunities for our members.

So, I hope you may be inspired by the new set of Bylaws and the new Strategic Plan that should be available towards the end of the year.

From the Vice President for Workshops & Symposia

Gerardo “Gerry” Acosta, VP for W&S

This year started with great energy in terms of workshops and symposia activities at our OES. And the horizon that is warned continues to be one of a lot of activity. This is very good since it shows us a community of members and volunteers eager to share experiences and practical and theoretical knowledge, networking and generating ideas together. This is knowing how to take advantage of the opportunities that IEEE OES offers us. We see part of this activity carried out this year reported in this issue of our Beacon.

Last March, we saw the successful completion of the *IEEE/OES Thirteenth Current, Waves and Turbulence Measurement (CWTM)* in Wanchese, NC, USA, while in April three relevant events took place for our Society. One without a doubt was the great *OCEANS Conference in Singapore*. Also there, the traditional underwater autonomous vehicle competition, *SAUVC*, was held days before, in which students from all over the world enjoy a few days of learning and consolidating knowledge in this exciting technology, in an atmosphere of great camaraderie. And if this were not enough, on 13 and 14 April they also organized the *IEEE OES Summer School 2024* themed “Observing our Ocean.” Congratulations to our people in Singapore for their excellent work last month. Meanwhile, on the other side of the planet, precisely in Portland, OR, USA, OES sponsored the *SusTech 2024–11th Annual IEEE Conference on Tech 4 Sustainability*.

In a few days during May, we look forward to the *2024 OES China Ocean Acoustics Conference*, in Harbin, China.



During June, the French OES Chapter is organizing the *French Top Experts Festival at Toulon*, which promises to be a fruitful meeting between professionals, academics, students and experts on topics of great interest to those passionate about the sea.

July promises us the first holding of the *Symposium on Maritime Informatics and Robotics*, organized by the University of the Aegean, in Syros, Greece, with OES patronage.

September awaits us with three events. The *Ucomms Conference 2024* will be held the first week of the month in Sestri Levante, Italy, co-organized with the RSMC. Also in Italy, but this time in Bolzano, OES will be collaborating with the *Automatica 2024* congress. And in Boston, MA, USA, the prestigious *2024 OES AUV Symposium* will take place, from 18 to 20 September.

October has an even greater offer. The first event will be the traditional *2024 Breaking the Surface*, in Biograd na Moru, Croatia, supported by our OES among other sponsors, and carried out by the Faculty of Electrical Engineering and Computing of the University of Zagreb. The *2024 OES MIW–Marine Imaging Workshop* will be held in Monterey, CA, USA, with the support of the local MBARI. Subsequently, the *USYS–IEEE 10th International Conference on Underwater System Technology: Theory and Applications* will be held in Xi’an, China, with the support of the local Northwestern Polytechnical University. Finally in Portoroz, Slovenia, *Metro Sea 2024–IEEE International Workshop on Metrology for the Sea* will take place.

Our Society will also be present at the *2024 IEEE International Workshop on Technologies for Defense and Security*, to be held in Naples, Italy in November. As well as in the *25th Biennial Conference on Biology of Marine Mammals* in Perth, Australia, also in next November. During the last week of November, we also secured our presence as OES at the *IEEE International Humanitarian Technology Conference (IEEE IHTC)*, thanks to the energy that our local Italian chapter puts into all activities linked to the ocean.

For 2025 we also already have many events planned. A new edition of *UNWis - Winter School on Underwater Network Simulations and Experimentation* in Padova, Italy. The first edition of *OES Breaking the Surface* outside Europe, in South America, more precisely in Buenos Aires, during the first week of February. In March, Taipei, Taiwan, awaits us with the *2025 IEEE OES Underwater Technology (UT) symposium* and we will wait for the new editions of the *2025 French Top Experts Festival at Toulon, RAMI-Robotics for*

Asset Maintenance and Inspections-Marine Robots Competition 2025, *2025 Symposium on Maritime Informatics and Robotics*, as well as the European version of *Breaking the Surface 2025*.

If you wish to get involved in these workshops or propose new ones, please contact me at vp-workshops-symposia@ieeeco.org. In addition, keep in mind that our OES offers the possibility of both technical and financial sponsorship, as well as patronage with grants for students and young professionals. In order to consider the latter in the budget, it is necessary to submit requests for support during the first half of the calendar year. Specifically, until the last days of May for the W&S that want to be held during the following year. On our website, there is a detailed guide for these presentations (<https://ieeeco.org/conferences/workshops-and-symposia/>) and if you have any questions, do not hesitate to contact me.

Have a safe and pleasant navigation and always tell me how I can help you!

VP OCEANS Report

Venugopalan Pallayil, Vice President for OCEANS (VPO)

Dear OES Colleagues,

After a gap of 18 years, with no bird flu or Covid-19 pandemic to impact us this time, Singapore hosted its second in-person OCEANS conference successfully during 15 to 18 April 2024. This was the 74th instance of OCEANS conferences. The conference was held at the Sands Expo Convention Centre, Marina Bay Sands, one of the top conference centers in Singapore. One unique feature of OCEANS 2024 Singapore was that all the conference events were held at the same venue and spread around the same floor so that the delegates could move between technical sessions, poster sessions, plenaries, panel discussions and the exhibition freely and easily. We estimate a total footfall of 900 attendees with over 300 trade visitors to the exhibition. The report on the final conference statistics is still under preparation. On behalf of the Local Organising Committee (LOC), and also as IEEE OES VP for OCEANS Conferences, my sincere thanks to all the attendees who made the conference a big success.

We also held two satellite events prior to OCEANS, primarily to engage students. These are the Singapore AUV Challenge (SAUVC), an autonomous underwater competition for tertiary students, and the Summer School. SAUVC has been held since 2013 while the Summer School was being conducted for the first time. Both these events were well attended and have been organized under the auspices of the IEEE Oceanic Engineering Society. The details of all these events have been covered elsewhere in this edition of Beacon Newsletter. The Marine Technology Society had also



organized an event, namely MATE ASEAN Regional ROV competition, prior to the OCEANS 2024 Singapore. It is now time to focus our time and energy towards OCEANS 2024 Halifax, which is scheduled for 23-26 September 2024 at the Halifax Convention Centre. You can find the details of the conference here: <https://halifax24.oceansconference.org>. If you wish to run special tracks, panels etc., get in touch with the relevant local organizing committee chair and submit your proposals. I would also like to call up on the society leads to plan and propose ancillary events, such as Student Mixer, Young Professional panel, Women in Engineering panel, etc., during OCEANS Halifax. Future OCEANS organisers may also want to take up the opportunity to promote their OCEANS at the Halifax event. We had both OCEANS 2025 Brest and OCEANS 2026 Sanya promoting their conferences at their complimentary booths provided by the conference during OCEANS 2024 Singapore.

We are also looking at improving the quality of papers being presented at OCEANS conferences. VPO held discussions with a selected group of senior OES members during the OCEANS 2024 Singapore and formulated certain recommendations which will be submitted for the consideration of OCAENS Steering Committee (OSC) for adoption.

On the OSC front, as mentioned in my last report, attempts to recruit a Conference Manager (CM) and a Professional Conference Organiser (PCO) is progressing. We have received many proposals, which are being curated and reviewed. We hope to have this exercise completed over the next few months.

In the interim, we are also looking into a proposal from a PCO who has offered to assist on the conference manager role until a permanent solution is in place. They will help with recommendations on future OCEANS conference site selections, expanding the conference reach as well as achieving more revenue through innovative marketing efforts. A decision on this is expected by the end of June, 2024.

After a long delay, the Limerick OCEANS audit is finally being scheduled. An auditor acceptable to the PCO and the conference sponsors has been identified and an engagement letter is being prepared. We hope to complete this exercise by

the end of May, 2024. Works to engage an auditor for Gulf Coast OCEANS is also in progress.

Brest and Great Lakes OCEANS preparations are also underway. IEEE OES is looking at organising new events alongside OCEANS to engage our community better. I will be providing more information on this in our next edition of Beacon Newsletter.

Are you being provided with relevant and sufficient information on OCEANS conference related activities? Your Feedback is important and let us keep in touch at vp-oceans@ieeooes.org.

From the Journal Editor's Desk

Karl von Ellenrieder, Journal Editor-in-Chief

Just having returned from attending a fantastically well-organized and scientifically interesting OCEANS 2024 Singapore, I would like to thank all the authors and Associate Editors who met with me during the conference. I would also like to remind the authors of OCEANS conference papers that they are welcome to develop their short conference papers into significantly longer manuscripts and to submit them for consideration for publication in the Journal. For information about how to do this, I encourage interested OCEANS Conference authors to refer to the editorial by EiC Emeritus N. Ross Chapman, which can be found online at the following link—<http://dx.doi.org/10.1109/JOE.2014.2313375>.



The Journal has received a high volume of manuscript submissions over the last several months, which is a great sign, but which also means that the workload of individual Associate Editors (AEs) has been high. To help manage the workload, several new AEs have been recruited to the Journal's Editorial Board. The appointments bring expertise in new areas of Oceanic Engineering importance, such as the application of machine learning, AI and reinforcement learning to traditional JOE research topics, including acoustic and optical underwater image processing, marine vehicle control and navigation, and ocean renewable energy. I would like to welcome the following new AEs to the Journal:

- 1) Riccardo Costanzi, University of Pisa, Italy - Marine Robotics, Autonomous Vehicles, Navigation, Cooperation, Perception, Underwater Computational Vision.
- 2) Hua Li, Hainan University, China - Underwater Image/Video Processing, Underwater Computer Vision, Machine Learning.
- 3) Traci Neilsen, Brigham Young University, USA - Underwater Acoustics, Source Localization and Characterization, Geoacoustic Inversion, Seabed Parameterization, Deep Learning Applied to Ocean Acoustics.
- 4) Peng Ren, China University of Petroleum, China - Underwater Imaging, Ocean Remote Sensing, Marine Environmental Forecasting and Prediction.

- 5) Alessandro Ridolfi, University of Florence, Italy - Marine Robotics, Underwater Vehicles, AUV Design, Autonomous Underwater Navigation, Automatic Target Recognition.
- 6) Yan Song, Shandong University, China - Sidescan Sonar, Machine Learning, Sonar Imaging, Planning and Decision-Making, Underwater Vehicles.
- 7) Yufei Tang, Florida Atlantic University, USA - Machine Learning, Data Mining, Dynamic Systems, and Ocean Renewable Energy.
- 8) Yu Wang, Chinese Academy of Sciences, China - Underwater Robots and Underwater Unmanned Systems.
- 9) Yifan Zhou, Stony Brook University, USA - Modeling, Dynamic Analysis, and Control of Ocean Renewable Energy (ORE) Systems; the Electronic-Interfaced Integration of ORE into Power Grids; and the Application of Artificial Intelligence and Machine Learning in Marine Energy Systems.

Finally, congratulations to the authors of our most recently approved papers. The following papers were published as Early Access papers on IEEE Xplore and will appear in a regular quarterly issue of the Journal soon. You'll find these papers online now:

- Yan-Tsung Peng, Yu-Cheng Lin, Wen-Yi Peng, Chen-Yu Liu. Blurriness-Guided Underwater Salient Object Detection and Data Augmentation.
<http://dx.doi.org/10.1109/JOE.2023.3344154>
- Cheng Chi, Shiping Chen, Rongxing Zhong, Pengfei Zhang, Peng Wang, Yu Li, Jiyuan Liu, Haining Huang. Robust Chinese Remainder Theorem-Based Synthetic Aperture Sonar Motion Estimation.
<http://dx.doi.org/10.1109/JOE.2023.3328084>
- Wojciech Maleika. Local Polynomial Interpolation Method Optimization in the Process of Digital Terrain Model Creation Based on Data Collected From a Multibeam Echosounder.
<http://dx.doi.org/10.1109/JOE.2024.3353271>

- Giovanna Inserra, Andrea Buono, Ferdinando Nunziata, Maurizio Migliaccio, Flavio Parmiggiani, Giuseppe Aulicino. Characterization of the Terra Nova Bay Polynya Using Dual-Polarimetric C-Band SAR Measurements. <http://dx.doi.org/10.1109/JOE.2024.3356569>
- Mohammed Elamassie. Path Selection in Parallel Multihop UVLC Systems Over Turbulence Channels. <http://dx.doi.org/10.1109/JOE.2024.3360532>
- Jianqun Zhou, Yang Li, Hongmao Qin, Pengwen Dai, Zilong Zhao, Manjiang Hu. Sonar Image Generation by MFA-CycleGAN for Boosting Underwater Object Detection of AUVs. <http://dx.doi.org/10.1109/JOE.2024.3350746>
- Brian T. Hefner, Dajun Tang, William S. Hodgkiss. The Impact of the Spatial Variability of the Seafloor on Mid-frequency Sound Propagation During the Target and Reverberation Experiment 2013. <http://dx.doi.org/10.1109/JOE.2024.3361968>
- Alfie Anthony Treloar, Hugh Maclean, Jan Bujalka, Jon Naramore, Ben Thomas, Philippe Blondel, Alan Hunter. Real-Time In-Situ Passive Acoustic Array Beamforming From the AutoNaut Wave-Propelled Uncrewed Surface Vessel. <http://dx.doi.org/10.1109/JOE.2024.3365169>
- Yushan Sun, Haotian Zheng, Guocheng Zhang, Jingfei Ren, Guoyang Shu. CGF-Unet: Semantic Segmentation of Sidescan Sonar Based on Unet Combined With Global Features. <http://dx.doi.org/10.1109/JOE.2024.3364670>
- Fan Wu, Haiyang Yao, Haiyan Wang. Recognizing the State of Motion by Ship-Radiated Noise Using Time-Frequency Swin-Transformer. <http://dx.doi.org/10.1109/JOE.2024.3369663>
- Hai Long Su, Peng Lang Shui. Fast Estimation of Complex High-Resolution Range Profiles of Ships via Amplitude-Position Bi-Iterative Sparse Recovery Algorithm. <http://dx.doi.org/10.1109/JOE.2024.3369707>
- Benjamin Thomas, Ciaran Sanford, Alan Hunter. Occlusion Modeling for Coherent Echo Data Simulation: A Comparison Between Ray-Tracing and Convex-Hull Occlusion Methods. <http://dx.doi.org/10.1109/JOE.2024.3369861>
- Francois-Xavier Socheleau, Christophe Laot, Sebastien Houcke. Cyclostationary Feature Distortion for Secure Underwater Acoustic Transmissions. <http://dx.doi.org/10.1109/JOE.2024.3366283>
- Shuqin He, Liyun Bai, Hao Zhou, Yingwei Tian, Da Huang, Caijun Wang, Jing Yang. Analysis and Suppression of Range-Domain Periodic Interference in High-Frequency FMICW Radar. <http://dx.doi.org/10.1109/JOE.2024.3353376>
- Zhongguang Li, Shuang Liang, Mingming Guo, Hua Zhang, Heng Wang, Zebin Li, Haoyang Li. ADRC-Based Underwater Navigation Control and Parameter Tuning of an Amphibious Multirotor Vehicle. <http://dx.doi.org/10.1109/JOE.2024.3353413>
- B. Paduano, F. Carapellese, E. Pasta, M. Bonfanti, S. Sirigu, D. Basile, D. Pizzirusso, N. Faedo, G. Mattiazzo. Experimental and Numerical Investigation on the Performance of a Moored Pitching Wave Energy Conversion System. <http://dx.doi.org/10.1109/JOE.2024.3353372>
- Zachary L. Cooper Baldock, Paulo E. Santos, Russell S.A. Brinkworth, Karl Sammut. Hydrodynamic Analysis of Payload Bay Berthing for Underwater Vehicles. <http://dx.doi.org/10.1109/JOE.2024.3352714>
- Jessica E. Carilli, Regina A. Guazzo, Angelica R. Rodriguez. Applying an Uncrewed Surface Vessel to Measure Under-Pier Bathymetry. <http://dx.doi.org/10.1109/JOE.2024.3360515>
- Isaac Skog, Magnus Lundberg Nordenvaad, Gustaf Hendeby. Signals-of-Opportunity-Based Hydrophone Array Shape and Orientation Estimation. <http://dx.doi.org/10.1109/JOE.2024.3357937>
- Jichen Chu, Lei Cheng, Wen Xu. Spatial Power Spectrum Estimation Under Strong Interferences Using Beam-Space Fast Nonnegative Sparse Bayesian Learning. <http://dx.doi.org/10.1109/JOE.2024.3365799>

Request for Nominations for OES Awards 2024

Jerry Carroll, Chair of IEEE/OES Awards Committees

Each year at the beginning of January, the Oceanic Engineering Society is proposing a call for four Awards, with a **closing date of June 30th**. A reminder call for nominations is issued mid-March. The Awards Committee requests the nominator to provide the listing of qualifications of the nominee relevant to the award criteria, and up to 5 references, by filling the Awards Nomination on-line form (<https://ieeoes.org/menu/award-forms/oes-awards-nomination-form/>).

The Awards descriptions are given below.

Request for Nominations for DTAA: The Distinguished Technical Achievement Award 2024

The Distinguished Technical Achievement Award is given to honor an outstanding technical contribution to oceanic engineering in either the fundamental or applied areas. The award recognizes either a single major invention or scientific contribution or a distinguished series of contributions over a long period of time.

Request for Nominations for DSA: The Distinguished Service Award 2024

The Distinguished Service Award is given to honor an individual IEEE OES member for outstanding contributions towards furthering the objectives of the Oceanic Engineering Society.

Company/Institution Award

The award will be presented to a corporation or institution that has significantly supported the activity and goals of OES through such areas as conference participation, patronage, technical innovation and technical or administrative participation.

Emeritus Award

The award will be presented to an OES member having been particularly important for the Society and who is no longer in any position of Society governance.

For more info, please visit the OES website as below:
<https://ieeoes.org/menu/award-forms/>

*Jerry Carroll

*Chair of IEEE/OES Awards Committees
past-president@ieeoes.org

IEEE YP Committee Meeting

Francesco Maurelli, OES YP-BOOST 2023–2024

YP, SAC, WiE, MGA, TAB, PSPB, CSTF... and then RAS, OES, MTTs, ITSS, TEMS... What are all these strange words and abbreviations? Welcome to the IEEE World, with its multi-faceted organisational levels. With more than 400,000 members in more than 160 countries, it is not a surprise that the world's largest technical professional society has many subdivisions in order to properly operate. I had the opportunity to learn more at the joint SAC/YP/WiE meeting, which happened in Lisbon from the 14th to the 17th of March, 2024, representing our own Oceanic Engineering Society Young Professionals. Let's start then to understand the abbreviations of the meeting name. SAC is Student Activity Committee, YP stands for Young Professionals and WiE – probably the most well-known abbreviation in the list – represents Women in Engineering.

OES members who actively follow the society's activities would surely recognise that we are active in all these areas. Similarly, other IEEE societies have activities in these areas as

well. And we should not forget the IEEE Regions: the world has been split into 10 regions and each of them has its own internal structure, with SAC, YP, WiE and so on.

The meeting in Lisbon aimed at getting all key people together, considering both the technical societies and the geographical areas.

Some parts of the program were in common for all three groups, whilst individual meeting rooms were reserved for the individual program, in order to focus on those specific elements relevant for each specific group.

The format of the event was a healthy mix of presentations, group discussions and activities, leaving little time to explore the beauty of the Portuguese capital. Properly designed to support networking, sharing best practices and activity ideas, the event flew very quickly, leaving long-lasting impact among the participants.

Among the areas of discussion, the transition from student to young professional and the involvement of industrial



Before the Keynote Talk of Prof. Dr. Isabel Trancoso, about her incredible research journey and the IEEE Fellows committee.



Stephanie Berrio Perez – YP Intelligent Transportation Systems Society, Francesco Maurelli – YP Oceanic Engineering Society, Ezio Malis – YP Robotics and Automation Society.

partners are challenges, which prompted a reflection on the membership value for people in those categories.

My personal three key take-aways from this event, linked to OES:

- There are no—or there should not be—walls among the 39 IEEE Societies. There are several overlaps, and we should focus on synergies between societies and between people. At OES we are perfectly placed to contribute and lead inter-society activities, as many can relate to ocean infrastructures, sensors, systems, vehicles and so on.
- Climate and Sustainability are top in the IEEE Agenda. To use the words of Prof. Dr. Saifur Rahman, IEEE Past President, the Institute goal is to provide engineering solutions to address climate change and sustainable development chal-

lenges. This is the way he has presented IEEE to various stakeholders and to the general public. The Oceans are a vital climate stabiliser and with the Ocean Decade Initiative, OES is perfectly in line with the overall IEEE global direction.

- IEEE is the natural home for every engineering professional. The needs are however different from a student to a professor, from a researcher to an industrial employee to a leader. The challenge for individual societies like OES is to show the value for the membership cost, especially when we are talking about industrial members who do not regularly attend conferences.

Overall, it was a fantastic experience, and I am now working to realise some of the ideas that came from the brainstorming and discussions in this event, like an IEEE Ocean Challenge!

Chapters' Meeting in Singapore

Maurizio Migliaccio, Chapters Coordinator and Shyam Madhusudhana, VP for Technical Activities

Singapore hosted the perfectly organized IEEE OCEANS 2024 Conference, Fig.1. Singapore is among the 20 smallest countries in the world, with a total land area of only 682.7 square kilometers. In addition to its main island, the nation of Singapore includes 63 additional islands, most of which are uninhabited. Singapore is one of only three surviving city-states in the world. The other two are Monaco and the Vatican City. The city of Singapore is distant, about 5314 km to Tokyo, 3806 km to Shanghai, 897 km to Jakarta, 3250 km to Taipei, and only 316 km to Kuala Lumpur.

The English name of Singapore is an anglicization of the native Malay name for the country, Singapura, which was in turn derived from the Sanskrit word for “lion city.” According to legend, this name was given to this land by the prince of Sumatra, who, during a hunting trip, spotted a strange creature that moved quickly, identified as a lion. Given the absence of

lions in that area, it is believed that it was a tiger, as tigers were found in the wild in Singapore until the 1930s.

As a matter of fact, half fish and half lion, the Merlion is an icon of Singapore that you will easily find reproduced on every corner of the city. The statue was designed in 1964, as a representative image of Singapore’s Ministry of Tourism, see Fig. 2.

Singapore is a city full of large green spaces. It is also called the “Garden City,” in fact, almost half of Singapore’s surface area is covered by green areas. You can also visit various natural reserves characterized by a very rich biodiversity.

Singapore is an important place in the world economy and finance. Its economy has been consistently ranked as the most open in the world and the financial Heart of Singapore, the Downtown Core, was just in front of the Sands Expo & Convention Center.

A last curiosity, among others, about Singapore is that the Government of Singapore was the first to develop a digital twin of the city. The project is known as Virtual Singapore (VSg) and is based on a set of real data and topographical data.

The Conference venue was at the Sands Expo & Convention Center on April 14–18, 2024, a perfect venue to have a



Figure 1. Singapore in Asia.



Figure 2. The Merlion.



Figure 3. The Sands Expo & Convention Center, Singapore.



Figure 5. Pictures taken during the Chapters' meeting.



Figure 4. The Canadian representative at the Canada pavilion.

meeting of the IEEE OES community and the Chapter Chairs, see Figs. 3.

As Chapter Coordinator and VP for Technical Activities, we enjoyed taking the opportunity to meet several Chapter Chairs in attendance at OCEANS 2024.

We had the chance to have in Singapore Gerardo Acosta, Argentina Chapter Chair, Philippe Courmontagne, France Chapter Chair, Marina Frederik, Indonesia Chapter Chair, Masanao Shinohara, Japan Chapter Chair, Weimin Huang, Newfoundland Chapter Chair, Nuno Cruz, Portugal Chapter Chair, Lian Lian, Shanghai Chapter Chair, Jenhwa Guo and his colleague, on behalf of Taipei Chapter Chair, Bharath Kalyan, Singapore Chapter Chair and of course the Italy Chapter Chair.

The meeting was hosted in the Canadian Pavilion, and we have to thank them for the hospitality, see Fig.4.

After the online meetings held on 12 March, 2024, it was so important to meet in person and have a positive and vibrant discussion on how to enhance the Chapter activities and to make them stronger and more and more attractive.

Although the meeting was organized in a short time, it was a successful meeting with the large part of Chapter Chairs present, see Figs. 5.

One of the first actions is to ask all IEEE OES Distinguished lecturers to have at least an online lecture before August. Such events can be jointly organized by different Chapters and since some DLs were present or contacted during the Conference they will soon have their lectures. All Chapters are invited to take such an opportunity and all DLs are invited to contact us to organize their seminars in the best possible way.

Further, it is important to also involve professionals, academics and students that are involved in marine science and technology but are not part of the IEEE OES family.

Finally, at the end of 2024 and in 2025, we aim at organizing three geographically distinct PhD schools, one in Europe-Africa, another in Asia-Oceania and the third one in America.

Chapters can greatly support the Society and take benefit of DLs and Technical Committees. Further, for small Chapters it is important to promote joint events with other Chapters, reaching out to new professionals not yet involved in OES.

Chapter News

Submit Chapter News to Beacon Co-Editors and OES Chapter Coordinator

Malaysia Chapter

IEEE-OES Distinguished Lecturer Talk by Visiting Professor Suleman Mazhar on Deep Learning Architectures for Underwater Communication at Universiti Teknologi Malaysia

Reported by Assoc. Prof. Ir Dr Zool Hilmi Ismail, Chapter Chair

On March 13th, 2024, Dr. Suleman Mazhar, a visiting professor from the Acoustic Science and Technology Laboratory, Harbin Engineering University, China, delivered an IEEE-OES Distinguished Lecturer Talk on Deep Learning Architectures for Underwater Communication at the Center for Artificial Intelligence and Robotics, Universiti Teknologi Malaysia, Kuala Lumpur. Dr. Mazhar, renowned for his contributions to



Figure 2. Researchers attentively listening to Prof. Dr. Suleman Mazhar.



Figure 1. Promotional poster for an engaging session led by Prof. Dr. Suleman Mazhar from the Acoustic Science and Technology Laboratory, focusing on advanced DL architecture for underwater communication.

Information & Communication Engineering, brought a deep reservoir of knowledge in Machine Learning, Signal Processing, and Underwater/Environmental Acoustics. His research is primarily focused on the application of deep learning and signal processing in environmental monitoring, medical imaging, and transportation systems.

The event was a significant highlight within the IEEE OES distinguished lecture series, designed to promote the exchange of knowledge and foster collaboration between the realms of academia and industry in the burgeoning field of deep learning and underwater communication technologies.

During his presentation, Dr. Mazhar offered a comprehensive overview of the myriad challenges inherent in underwater acoustic (UWA) communication, including the unpredictable and dynamic nature of acoustic channels, influenced by Doppler spread, low signal-to-noise ratios (SNR), and the overarching complexity of channel characteristics, further compounded by a scarcity of real-world data. He meticulously detailed how recent deep learning-based models have been adeptly employed to surmount these challenges, focusing on end-to-end deep learning models for orthogonal frequency division multiplexing (OFDM) communication and deep learning-based channel estimation problems, showcasing recent advancements made by his laboratory at Harbin Engineering University.

The session was not only technical in nature but also highlighted the myriad opportunities in marine conservation and bioacoustics for students and young researchers. Dr. Mazhar, serving in various capacities such as the chair of the OES-SOI Berth of Opportunity committee, mentor for the IEEE-SPS ME-UYR Program, and chair of the Student Activities Committee (IEEE-OES), emphasized the importance of leveraging technological innovations in environmental stewardship and conservation efforts.

The engaging Q&A session that followed his presentation saw a lively exchange of ideas and inquiries from faculty

members, postgraduate students, researchers, and AI practitioners. This session not only solidified Dr. Mazhar's status as a luminary in the field but also paved the way for future collaborative endeavors between Harbin Engineering University and Universiti Teknologi Malaysia, underscoring the critical importance of interdisciplinary research in addressing the complex challenges faced by our oceans and highlighting the promising future of deep learning in advancing our capabilities in underwater communication.

Japan Chapter

The 11th Underwater Technology Forum · ZERO HYBRID

Reported by Harumi Sugimatsu

The 11th Underwater Technology Forum · ZERO was held from 13:00-17:00 on 26 April, 2024, on the Institute of Industrial Science, The University of Tokyo in Meguro Research Campus (<https://seasat.iis.u-tokyo.ac.jp/UTforum/>). This time, we had 108 in-person attendees and 192 online attendees. Among the speakers, two Japanese youth who are working in France and England were online, and one speaker who was joining the field-work in Pakistan (no internet access) sent us the video presentation in advance.

From this forum, Prof. Asuka Yamaguchi of University of Tokyo has been the Forum Co-Chair along with Prof. Toshihiro Maki, instead of Prof. Yutaka Michida who has been elected as Chair of IOC.



Welcoming address by Prof. Toshihiro Maki, Forum Co-Chair.



Closing remark by Prof. Asuka Yamaguchi, Forum new Co-Chair.



From the talk "Discovery, exploration and the possibility of life in the "outer" earth oceans."

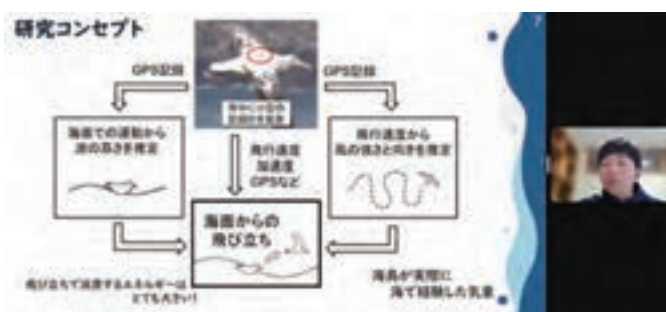

From the talk "Albatrosses flying in rough seas and stormy winds - Effects of local environmental conditions on seabirds."

Topics of the forum are as below:

- Discovery, exploration and the possibility of life in the "outer" earth oceans
- Challenges on the AUV "Shinryu6000" in rare-earth elements exploration
- Overview of port facilities damage survey for the 2024 Noto Peninsula Earthquake
- Wide area monitoring by satellite SAR
- Commercialization strategies and model-Based decision making for ocean utilization systems
- Fascination of underwater archaeology
- Albatrosses flying in rough seas and stormy winds - Effects of local environmental conditions on seabirds
- Challenges at "Vaarset", a British Underwater Robotics Venture - New developments in AUV technology and underwater 3D imaging

Since the topics covered were wide-ranging and exciting, the audience hardly had time to breathe during the forum.

I hope that we have also an enjoyable time for the next Forum, which will be held on the 11th of October, 2024, at the Atmosphere and Ocean Research Institute, The University of Tokyo in Kashiwa Campus. Please join us!

Call for OES Distinguished Lecturers 2025–27 Nominations Close on July 31, 2024

Shyam Madhusudhana, VP for Technical Activities

The IEEE Oceanic Engineering Society (OES) invites nominations for OES Distinguished Lecturers. The IEEE OES Distinguished Lecturers Program provides high quality speakers to the Oceanic Engineering Community, especially, OES Chapters, Student Branch Chapters, and Student Clubs. Appointment as an OES Distinguished Lecturer is a major Society recognition.

Requirements

Distinguished Lectures are meant to appeal to a broader audience and not just technical experts. So, the talks should be prepared accordingly to attract as many members as possible from OES community. Distinguished Lecturers are expected to have

- high technical proficiency in their area;
- demonstrated ability to make technical presentations that are inspiring to audiences of both experts and general audiences;
- OES membership throughout the term of their appointment.

Technology Committee (TC) Chairs and Administrative Committee (AdCom) members are strongly encouraged to make nominations as long as there is no conflict of interest in the selection process. Nominations from Chapters as well as self-nominations are encouraged. All nominations are to be endorsed by the relevant TC. So, if you are looking for a nominator, we encourage you to contact the chair of the most relevant OES Technology Committee. A nomination email to the Vice President for Technical Activities (VPTA) should include a brief CV (1 page) of the nominee, contact details for the nominee, the nominator and endorsement by the relevant Technology Committee Chair.

The Distinguished Lecturer Committee will consider nominations and shortlist candidates, taking into account the diversity of topics and geographic spread of the pool of Distinguished



Lecturers, in addition to the criteria given above. The selected Distinguished Lecturers will subsequently be approved by the OES AdCom.

Duties

The Distinguished Lecturers will start their three-year term in January 2025. Each Lecturer should submit topics in his/her field of expertise that will be posted on the Society website. The Distinguished Lectures should be readily available to travel within their geographical area upon contact by the Chapters or appropriate organizations and are expected to add small diversions to their international travels to present lectures whenever opportunities arise. Reasonable travel expenses will be paid by the Distinguished Lecturer Program based on the availability of funds.

Closing Date

Nominations for a three-year term 2025–27 close on **31 July, 2024**.

Decade of Ocean Science in the CWTM 2024 Workshop

Mal Heron and Weimin Huang, Co-Chairs of the CWTM 2024 Workshop

The Thirteenth Currents, Waves, and Turbulence (CWTM) Workshop was enhanced by support from the OES Ocean Decade Initiative (ODI) Ambassador Program under the guidance from Ambassador Mal Heron. The co-chair for the Workshop was Weimin Huang who is also Chair of the CWTMA Technology Committee.

Two student delegates were awarded ODI Scholarships to help their registration and travel costs to the CWTM Workshop. These were judged on their scientific innovation, their present-

ation and their alignment with the Decade of Ocean Science. Jacob Davis, from the University of Washington Applied Physics Laboratory, received an award for his paper “Multiscale measurements of hurricane waves using buoys and airborne radar.” Jacob combined air-deployed microSWIFT (UW-APL) and Spotter (Sofar) buoys together with the Wide Swath Radar Altimeter (WSRA), which flies aboard a NOAA Hurricane Hunter P-3. The mean square slopes measured by the two instruments were used to infer the high frequency tail of the



Mal Heron, Jacob Davis, Brendan Henley and Weimin Huang at the DOS awards presentation.



The DOS panelists Weimin Huang, Eric Gill, Mal Heron, Michelle Barnett and Jim Thomson.

wave spectrum, which is important for understanding wave-induced stress in hurricanes.

Brendan Henley, from Rutgers University, received his award for “Determining the seasonality of oceanic eDNA source waters.” Brendan used HF radar surface current data to estimate the seasonal movement of eDNA (environmental DNA) in coastal waters during 24-hour periods and beyond. These are early results in a technology that will provide impact assessment of fish species near off-shore infrastructures.

The panel session on the Decade of Ocean Science for Sustainable Development (DOOSFSD) was convened by Mal Heron. Mal’s introduction pointed to the community awareness and educational successes of DOOSFSD, but he emphasised that it is the task of organisations like OES to promote and apply science and technology to the aims of the Decade of Ocean Science. Four speakers were invited to speak to the four main topic areas of the CWTM Workshop.

Michelle Barnett, from Sonardyne, showed how ADCPs (Acoustic Doppler Current Profilers) contribute to a productive, healthy and resilient ocean for example in offshore renewable energy as well as in offshore aquaculture. The use of ADCPs continues to grow world-wide.

Jim Thomson, from the University of Washington, outlined the dramatic increase in the number and type of buoys that we have been experiencing, and are likely to see this continue into the future. “More buoys, more science” was Jim’s leading line. He also made the point that many buoys are decreasing in cost and are therefore more likely to be the technology of choice for developing countries and small island states.

Eric Gill, from Memorial University, made the point that innovation and improvement of technologies also needs sustainable development during the decade. HF radar has a special place in current monitoring because of the unique spatial and temporal coverage. Eric spoke of the challenges like tsunami detection, search and rescue operations, ship tracking and tracking of buoyant pollution.

Weimin Huang, from Memorial University, addressed the contribution of X-band radars to the Decade of Ocean Science. X-band radars on ships and at coastal locations provide data on currents, waves, and wind as well as being the basic navigational aid. During this decade, X-band radars will be used routinely for predicting individual wave amplitudes—which should mitigate the impact of rogue waves at sea.

Decade of Ocean Science in the SAUVC 2024

Bharath Kalyan, Hari Vishnu, SAUVC Organizing Committee

The IEEE OES Ocean Decade Initiative (ODI) Ambassador Programme, under the guidance of Ambassador Mal Heron, supported a panel session at the Singapore Autonomous Underwater Challenge (SAUVC) held on 5–8 April 2024 and reported separately in this issue of Beacon. The experience for this year’s SAUVC participants was further enriched by this session delving into the theme of “Navigating the Blue Frontier: Innovations in Ocean Technologies and Autonomous Systems for address-

ing Ocean Decade Challenges.” Distinguished speakers from various backgrounds were invited to the event, each providing unique insights into ocean exploration and technology. The panel session was moderated by Assoc Prof Mandar Chitre from National University of Singapore, who brought his underwater domain expertise and technical insights into the conversation, facilitating an engaging exchange of ideas among the panelists and the audience.

Speaker Insights:



Figure 1. The moderator, Mandar Chitre, and the five panelists, Raj Nagalingam, Eddann Arcena, William Kirkwood, Chinmay Pendharkar, Fikret Ercan.

Raj Nagalingam (FET Subsea, Singapore): Raj Nagalingam's extensive background in the ROV sector and his current role as the Regional Commercial Manager for FET Subsea provided a pragmatic outlook on the challenges and opportunities facing the industry. With over 25 years of field experience, Raj offered valuable insights into the operational, production, and sales aspects of subsea equipment, including Submarine Rescue Vehicles for naval operations. During the panel discussion, Raj highlighted the need for skilled professionals in various engineering disciplines, including hydraulic, electronic, electrical, software, and mechanical engineering, to support underwater operations effectively. His emphasis on the importance of workforce development and talent retention resonated with the audience, underscoring the critical role of education and training in preparing individuals for careers in the ocean technology sector.

Eddann Arcena (Fugro, Singapore): Eddann Arcena's role as a Vessel Technical Support Engineer and Technical Support Lead at Fugro discussed the practical applications of autonomous underwater vehicles (AUVs) in offshore industries such as oil and gas and renewable energy. With extensive experience working with Kongsberg Hugin-1000 AUVs, Eddann shared firsthand experiences from expeditions. During the panel discussion, Eddann highlighted the importance of detailed surveys for installing offshore wind farms and the transition from traditional oil and gas exploration to renewable energy sources like wind power.

William (Bill) Kirkwood (MBARI, USA): Bill Kirkwood's shared his extensive experience at MBARI in the development and utilization of cutting-edge oceanic instruments and vehicles (ROV Tiburon, AUV Dodaro). During the panel discussion, Bill emphasized the importance of leveraging technology to address pressing oceanic issues, including climate change, biodiversity loss, and habitat degradation. His insights underscored the critical role of research institutions and industry collaborations in advancing our understanding of the ocean and developing sustainable solutions for its conservation and management.

Chinmay Pendharkar (Subnero, Singapore): Chinmay Pendharkar highlighted the significance of integrating artificial intelligence (AI) and underwater communication technologies for ocean exploration and monitoring. With a background in engineering acoustics and experience working with experi-

mental audio technologies, Chinmay shared insights into the role of AI in optimizing underwater operations and enhancing communication capabilities. He also made comparisons regarding the utilization of these machine learning (ML) algorithms by the teams participating in SAUVC. During the panel discussion, Chinmay highlighted the importance of AI-driven decision-making processes, motion planning algorithms, and ML techniques in improving the efficiency and accuracy of underwater missions.

Fikret Ercan (Singapore Polytechnic): Dr. Fikret Ercan's role as an educator provided a unique perspective on the intersection of education, technology, and ocean exploration. He highlighted the importance of cultivating a skilled workforce equipped with the knowledge and expertise to address the challenges of oceanic exploration. He further underscored the critical role of technology in advancing our understanding of the ocean environment and developing innovative solutions to pressing issues. During the panel discussion, Dr. Ercan emphasized the need for educational initiatives that prepare students for careers in fields such as marine robotics, underwater acoustics, and data analytics.



Figure 2. ODI ambassador program panelists and SAUVC participants.

Key Takeaways:

- **AI Integration:** There was a consensus among panelists regarding the pivotal role of AI in oceanic operations, from autonomous ships making intelligent decisions to AI-driven structural surveys and assessments.
- **Manpower Challenges:** Panelists highlighted the imminent need for skilled professionals in the fields marine offshore industry, emphasizing the importance of continuous learning and adaptation to technological advancements.
- **Ocean Decade Challenges:** The discussion encapsulated the essence of the Ocean Decade Challenges, focusing on sustainability, collaboration, and the need for robust infrastructure to explore and study the ocean's depths.

The ODI Ambassador Programme supported a panel session at the SAUVC that provided a platform for industry experts to exchange ideas, envision the future of ocean technologies, and address pressing challenges facing our blue frontier. With sustainability, innovation, and collaboration at its core, the event left attendees inspired and equipped to navigate the vast expanse of our oceans.

OES Contributions to the UN Ocean Decade Conference

Laura Meyer, Chair, OES Ocean Decade Initiative Committee, Christopher Whitt, OES Ocean Decade Initiative Committee Member

Human activity is making our planet sick and, with it, our oceans. The increasing frequency of natural disasters is just the beginning, with global tipping points, such as Greenland’s melting ice sheets, raising sea levels and threatening coastal communities. Continuing business as usual by ignoring the planet’s signs will be costly to human health, the global economy, and biodiversity at large in the future. Accordingly, everyone should seek to protect the ocean.

The UN Decade of Ocean Science for Sustainable Development 2021-2030 (the Ocean Decade) has been a rallying force in the ocean science world, and we are proud to continue our support in its fourth year. This year, the first in-person UN Ocean Decade Conference was held in Barcelona, Spain, from April 10–12, 2024 (<https://oceandecade-conference.com/home.php>), and OES played a dynamic role. Our contributions, including organizing an off-site satellite event, providing a panelist for a second satellite event, and co-organizing an on-site session, have shown OES’s ongoing dedication to supporting the Ocean Decade.

OES’s Ocean Decade Initiative (ODI), active since 2022, is our tool to coordinate activities to raise awareness about the Ocean Decade within our own communities. The ODI also supports activities that promote engineering, technology, and innovation to advance the goals of the larger Ocean Decade. More information about the ODI can be found at ieeoeos.org/oceandecade/.



Laura Meyer moderating the OES satellite event “Emerging technologies for climate change mitigation.”

We hosted a satellite event on nature-based climate solutions. This panel delved into the technical and policy challenges of large-scale offshore seaweed farming. We explored how such industries could meet key societal needs, potentially replacing petrochemical sources and sequestering excess carbon dioxide for geologically significant time scales. This discussion highlighted the potential of nature-based solutions in addressing the climate crisis.

Our ODI Chair was invited to speak on a panel organized by the UN Early Career Ocean Professionals Programme (ECOPs). The strong sense of community among ECOPs, which we attri-

bute to this generation’s natural inclusivity, was uplifting. This panel underscored the potential of young professionals in driving change and addressing ocean sustainability challenges. It’s a testament that we can achieve our best outcomes when we draw on expertise from all disciplines and backgrounds.



ECOP Panel on “The inclusivity we need for the ocean we want.”

Yet young, aspiring ocean scientists and engineers face many challenges. This panel discussed some of those. Unfortunately, the international cohort of ECOPs was smaller than anticipated because delegates, particularly from developing nations, are more likely to face long and complicated visa applications to attend international conferences relative to ECOPs from Europe or North America. The difficulty of obtaining visas highlighted the need for more inclusive planning and support mechanisms to ensure broad participation in such international events.



Technology and Innovation Showcase on-site satellite event.

Finally, we contributed to the on-site satellite event organized by the Ocean Decade’s Technology Innovation Working Group (TIWG). This panel session featured ten lightning talks. Each three-minute lightning talk was a pitch for a technology that already exists, ready to fill a climate solution need or an opportunity that demands technological innovation to be applied. This gave an interesting and broad perspective on how technology holds massive potential for achieving better measurement, monitoring and management of the essential ocean resources society needs.

The Ocean Decade Conference was motivating and inspiring, showcasing the importance of young professional involvement in the global dialogue on ocean sustainability. The OES ODI is planning panels and other climate solutions activities for OCEANS 2024 Halifax, organizing a technical webinar on

automated shipping for the IEEE Government Engagement Series, and planning a call for OES Student Branch Chapter activity proposals. If you want to be involved in the OES ODI, email oceandecade.oes@gmail.com or complete this form: <https://forms.gle/fX6QHkEjW7dxwPvF8>.

OCEANS 2024 Singapore Ocean Decade initiative Panel: “Shifting Mindsets, Overcoming Barriers”

Amelia Ritger, Department of Ecology Evolution and Marine Biology, University of California, Santa Barbara, Giulia De Masi, Research Program Manager and Visiting Faculty at Khalifa University, Abu Dhabi

Photos Courtesy: Hari Vishnu, Acoustic Research Laboratory, National University of Singapore

Various Ocean Decade Initiative activities are being conducted under the OES Ocean Decade Initiative Program. Here is an introduction of the OES sponsored panel at OCEANS 2024 Singapore (<https://singapore24.oceansconference.org>). If you are interested in the OES Ocean Decade Initiative Program, please visit the URL <https://ieeoes.org/oceandecade/> for more info.

“The ocean plays a crucial role in the achievement of the Sustainable Development Goals and the livelihoods of billions of people. We urgently need to change how we interact with it.”

– United Nations Secretary General António Guterres

To achieve the ambitious goals of the United Nations Ocean Decade, we need to change not only how we interact with our ocean, but also how we interact with each other. The OCEANS 2024 Singapore panel “UN Ocean Decade: Shifting Mindsets, Overcoming Barriers”—organized by Francesco Maurelli (Assistant Professor at Constructor University in Bremen) on behalf of the OES Ocean Decade initiative committee—underscored the critical role of collaboration, behavioral change, and stakeholder empowerment in tackling the complex challenges facing our oceans.



The panel session was engaging and well-attended.

The panel emphasized that by fostering collaboration across disciplines and leveraging insights from behavioral science, we can develop and implement more effective solutions that address global climate change and ensure a healthy ocean for future generations.

The panel was moderated by Francesco Maurelli and featured the following panelists:

- Rakoen Maertens, Junior Research Fellow at University of Oxford
- Aazani Mujahid, Associate Professor at Universiti Malaysia Sarawak
- Filippo Campagnaro, Assistant Professor at Università degli Studi di Padova

The panel included both short presentations and an interactive component, with audience members providing responses to questions such as: “What can you identify as barriers to shifting mindsets in your field/project?”

The discussion unpacked the concept of “shifting mindsets” as a cornerstone for achieving the Ocean Decade goals. For example, we traditionally address problems from a technical perspective; however, the human element is woven into every step of project development, as we work on teams and with clients to develop successful solutions. By shifting our mindset to mindfully consider the human component in our work, we can better address the desires and needs of the human societies reliant upon a thriving ocean ecosystem.

The panel also explored methods for breaking down perceived barriers and highlighted how interdisciplinary collaboration, community engagement, and human-centered solutions are critical to tackling the complex challenges facing our oceans.

The Power of Collaboration

Filippo Campagnaro, co-founder of SubSeaPulse, showcased the power of a cross-disciplinary approach. He discussed the limitations of traditional data collection methods in ocean observations, which are often time-consuming, expensive, and require physical sampling in challenging environments. Sub-SeaPulse’s technology, born from collaborations with marine

biologists and aquaculturists, offers a cost-effective and scalable solution through wireless, real-time sensor networks. Campagnaro's work addresses several of the UN Ocean Decade challenges, including those related to ecosystem health assessment, building community resilience, and equitable access to data and technology, demonstrating the power of collaboration in tackling complex environmental issues.

The Importance of Community Engagement

Aazani Mujahid, a researcher from Universiti Malaysia, Sarawak, presented a compelling perspective that shifted the focus beyond science and engineering to identifying and addressing systemic issues.



Dr. Aazani Mujahid sharing her thoughts on the issues leading to low uptake in science stream, especially amongst women.

Her work engages fishing communities, particularly women, who are often excluded from scientific research and decision-making processes. Mujahid identified several barriers to greater community involvement, including cultural barriers, funding limitations, lack of education and alternative livelihood options, and disinterest in and distrust of science.

She highlighted the importance of empowering women in these communities to make significant social, economic, and environmental change, especially within their own community. Mujahid's work exemplifies the critical need to integrate social sciences and community engagement into ocean conservation efforts.

The Science of Human Behavior

Rakoen Maertens, an applied behavioral scientist from the University of Oxford, highlighted how behavioral science can offer valuable insights into how to effectively shift mindsets and promote sustainable behaviors.

He began by describing the benefits of behavioral science and showing how behavioral science is critical to making impactful changes in the fields of ocean science and engineering.

He also introduced fundamental ideas in behavioral science that have been developed to explain how and why people make the decisions they do. For example, seemingly small changes, or "nudges," have the power to significantly influence human behavior. To affect more complex behavior and generate long-term changes, however, we need effective interventions that bridge the "intention-behavior gap" where people have good intentions but lack motivation.

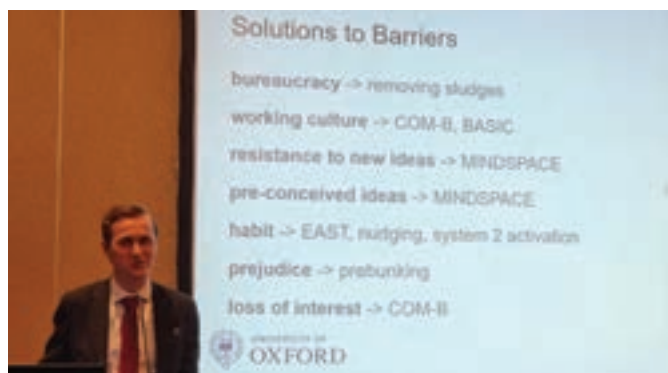

Dr. Rakoen Maertens delivering his talk at the panel, summarizing tools and techniques for applying or using behavioral science in oceanic engineering outreach.

Maertens cited frameworks and tools like MINDSPACE, COM-B, and BASIC that have been developed to design interventions that identify and target behaviors. He pointed out some resources that the audience could read to tap into the power of behavioral science (e.g., <https://www.busara.global/our-works/the-busara-toolkit-groundwork/>, <https://www.bi.team/publications/mindspace/>). Maertens concluded by emphasizing the need for proactive integration of behavioral science into projects, but cautioned against a one-size-fits-all application across different cultures.

Closing Thoughts

At the start of the session, the moderator, Francesco Maurelli, asked the audience to identify perceived barriers to shifting mindsets. Maertens built upon this at the end of the discussion by asking the audience to identify enablers to shifting mindsets and consider their own actions, asking: "What are YOU going to do (concretely) with the insights from this panel?"

Audience participation during this exciting session not only informed the discussion, but it also solidified the session's call to action, encouraging audience members to translate knowledge into an interdisciplinary and collective effort towards sustainable ocean science, engineering, and conservation.

Overall, the session shed light on the importance of changing mindsets and provided attendees with tools and approaches for achieving positive community change during the ongoing Ocean Decade.

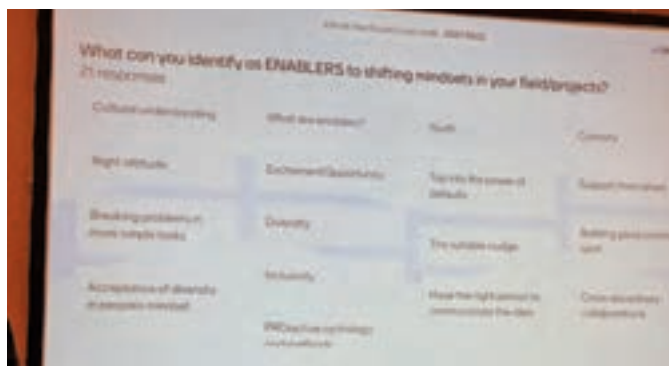

A summary slide of responses from the audience on what they identified as enablers in shifting mindsets in their respective fields.

OES Conference Calendar

Contact **BEACON Editors, OES VPWS and VPTA**

OCEANS

OCEANS 2024 Halifax

September 23–26, 2024

Halifax, Canada

<https://halifax24.oceansconference.org>

OCEANS 2025 Brest

June 16–19, 2025

Brest, France

<https://brest25.oceansconference.org>

IEEE-OES Summer School 2025

June 20–21, 2025

Brest, France

* More info will soon be updated.

OTC

OTC 2025

May 5–8, 2025

Houston, USA

<https://2025.otcnet.org>

OES Sponsored (financial or technical)

COA 2024

May 29–31, 2024

Harbin, China

<http://www.iccsnt.org/COA2024/index.asp>

UComms

September 3–6, 2024

Sestri Levante, Italy

<https://ucomms.net/index.php>

AUV2024

September 18–20, 2024

Boston, USA

<https://auv2024.sites.northeastern.edu>

MIW 2024

October 7–10, 2024

Monterey, USA

<https://miw2024.org>

2024 USYS

October 11–13, 2024

Xi'an, China

<https://usys2024.com>

Metro Sea 2024

October 14–16,

Portorose, Slovenia

<https://metrosea.org>

OES Patronaged

Automatica.it 2024

September 11–13, 2024

Bolzano, BZ Italy

<https://automatica2024.unibz.it>

BTS 2024

September 29–October 6, 2024

<https://bts.fer.hr>

TechDefense 2024

November 11–13, 2024

Naples, Italy

<https://www.techdefense.org>

IHTC 2024

November 25–27, 2024

Bari, Italy

More info will soon be updated.

Workshop: Advancing Marine Mammal Research through Machine Learning @ SMM2024

November 10, 2024

Perth, Australia

<https://www.smmconference.org>

Non-OES but OES Members are Involved in

Please contact us if you have any information about non-OES events that OES members are involved in.

OTC Asia 2024 in Person Meeting Again!

Harumi Sugimatsu, OTC Asia 2024 IEEE OES Program Sub-committee Chair



As a member of IEEE OES program Sub-Committee, I have been involved in the OTC Asia since 2018. Unfortunately, due to the COVID-19 pandemic, OTC Asia 2020 and 2022 were held in online and hybrid formats. This year, I was finally able to visit Kuala Lumpur to attend the OTC Asia 2024 in person. Below is an overview of

the conference, the Focus Session organized by OES, publicity at the OES booth and the exchange with the Malaysia Chapter.

Conference Summary

OTC Asia 2024 was held at the Kuala Lumpur Convention Center in Kuala Lumpur on 27 February to 1 March 2024 on the theme “Excellence in Asia—Energising Now and for the Future” (<https://2024.otcasia.org>). The Conference host was PETRONAS.

The 2024 conference scale is getting growth in the number of attendees (23,000 delegates from 80 countries) in comparison with the OTC Asia 2022 in hybrid (8,821 delegates, 91.8% of them were Malaysian). There were 182 exhibitors, 264 technical papers presented in 47 technical sessions (1,172 abstracts submitted, 399 abstracts selected), and 29 special panels/sessions/dialogues.

The IEEE OES Focus Session

The IEEE OES Focus Session—AUV and Ship Technologies was held on 1 March 2024. OES Japan Chapter has contributed to organize the panel. The key focus of this session was sharing the new era technologies of autonomous underwater vehicles (AUVs) and ships, and discussing further usage of AUV and ship technologies accelerating new offshore developments by



From Opening Ceremony at OTC Asia 2024.



From the exhibition at OTC Asia 2024.

contributing unmanned operations, underwater and sub-bottom survey, maintenance, and logistics.

Session Co-Chairs and speakers were as below.

Session Co-Chairs:

Keisuke Watanabe, Professor of Tokai University

Nori Kyo, Researcher, JAMSTEC

Presentation titles and speakers:

- 1) Autonomous Underwater Vehicles for Offshore Survey Application, by Martin Gutowski, Kongsberg Discovery
- 2) Seafloor environment investigation by a hovering type AUV “YOUZAN,” by Eiichi Kikawa, IDEA Consultants, Inc.
- 3) Unleashing the Potential of Multi-AUV-Based Advanced Unmanned Marine Vehicle Systems, by Kangsoo Kim, National Maritime Research Institute, National Institute of Maritime, Port, and Aviation Technology of Japan (NMRI)
- 4) High-rate acoustic communication and integration with acoustic positioning for multiple AUVs operation, by Takuya Shimura, JAMSTEC
- 5) LOC2-EP, efficient concept of liquid CO₂ carrier for CCS x Potential AUV opportunity as subsea, by Tomoki Inoue, Knutsen NYK Carbon Carriers AS



Speakers: Martin Gutowski, Eiichi Kikawa, Kangsoo Kim, Takuya Shimura, Tomoki Inoue, Autor and Session Co-Chairs: Keisuke Watanabe, Nori Kyo (L to R) at the session.

From the floor, many specific questions/discussions were raised about the actual use of AUVs in areas such as underwater pipe line maintenance for a CO2 carrier, and future technologies of long duration operation of AUVs (without the mother ship).

After the session, a lunch meeting was held with the panel attendees and OES Malaysia Chapter members.

OES Booth

The OES booth at the exhibition hall was well organized by the VPPA. Several AdCom and members of the Malaysia Chapter, including student members, volunteered at the OES booth to promote the OES and recruit new members. You can read the Malaysia Chapter's students report in this issue too.



Audience at the panel.

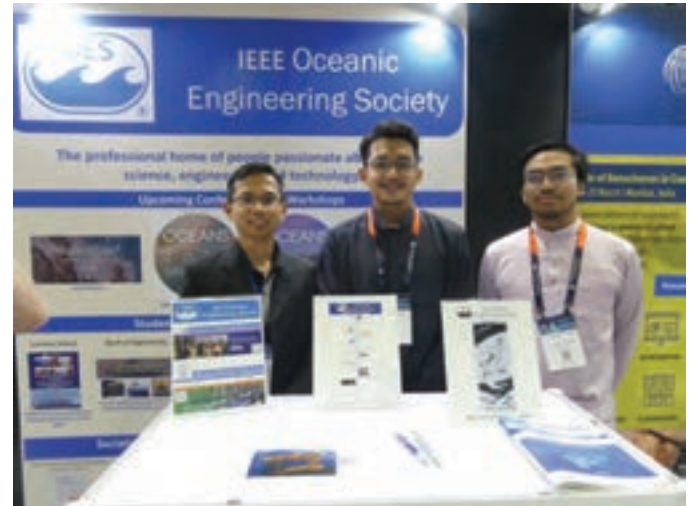

OES Malaysia Chapter Chair Zool H Ismail (L) and his students at the OES booth.

Here, I would like to thank all the people who supported the OES's activities for OTC Asia 2024. I would like to especially thank the Chairs and Speakers of the OES Focus Session, and also to the Malaysia Chapter members. This will set a good precedent for future LOC activities in locations where OES events will be held.

We look forward to welcoming you at OTC Asia 2026!



Lunch meeting after the focus session sponsored by OES Japan Chapter.

The presentations were followed by a discussion with the audience. A key aspect of the discussion was: What are the required/potential application of AUVs in the Oil and Gas industry?



Welcome to OTC Asia 2026 from the OES volunteers.

OTC 2024 Brief Summary

Elizabeth L. Creed, Vice President for Professional Activities

The OES is one of 13 sponsoring academic, scientific, and professional organizations of the Offshore Technology Conference (OTC). The OTC was founded in 1969 and is held annually in Houston, TX. In 2023 there were more 31,000 attendees. While two-thirds of the attendees were from the United States, the remaining one-third came from 103 other countries. This year the Conference was held from May 6–9, and was a success on many fronts. Overall attendance was good. The OES Technical Sub-Committee put together a diversified and robust program (see Table 1 below). There was good traffic in the exhibit hall. At our booth we welcomed new members to the IEEE OES. Several groups of attendees expressed interest

in starting OES Student Branch Chapters, and nine students participated in the OES’ CNET program—one of several programs at OTC that connects students and young professionals with employers looking to fill internship and full-time positions in their organization. The OES rounded out its activities at OTC with a Volunteer Luncheon where we recognized and thanked our OES Technical Sub-Committee members for a job well done.

If you are interested in serving on the OES Technical Committee for OTC Houston, OTC Asia, or OTC Brazil, please contact the OES Past President: past-president@ieeeco.org for more information.

Table. IEEE-OES Technical Program at OTC Houston 2024.

Day and Time	Topic	Sponsoring Society	Co-Sponsoring Society
Monday: 09:30–12:00	Advancements in Offshore Robotics Enabling Sustainable Exploration and Inspection	Institute of Electrical and Electronics Engineers, Oceanic and Engineering Society (IEEE-OES)	None
	All-Electric Subsea and Wells	Institute of Electrical and Electronics Engineers, Oceanic and Engineering Society (IEEE-OES)	None
Tuesday: 09:30–12:00	Energy Storage and Handling Intermittent Sources	Institute of Electrical and Electronics Engineers, Oceanic and Engineering Society (IEEE-OES)	None
Wednesday: 08:00–09:00	The Rise of Nuclear in the Offshore Domain	Institute of Electrical and Electronics Engineers, Oceanic and Engineering Society (IEEE-OES)	None
Wednesday: 14:00–16:00	Innovations in Subsea Technologies for Offshore Oil and Gas Fields	Institute of Electrical and Electronics Engineers, Oceanic and Engineering Society (IEEE-OES)	American Society of Mechanical Engineers (ASME)
Thursday: 09:30–12:00	Digitalization and Improved Safety in Oil and Gas	Institute of Electrical and Electronics Engineers, Oceanic and Engineering Society (IEEE-OES)	None
	Artificial Intelligence, Machine Learning, and Advanced Analytics for Enhanced Operations and Recovery	Institute of Electrical and Electronics Engineers, Oceanic and Engineering Society (IEEE-OES)	American Institute of Chemical Engineers (AIChE)
Thursday: 12:30–13:30	Upstream Research and Development at Aramco+	Institute of Electrical and Electronics Engineers, Oceanic and Engineering Society (IEEE-OES)	None
Thursday: 14:00–16:30	How Digital Tools and Robotics are Enabling the Next Step in the Evolution of Subsea Activities	Brazilian Petroleum, Gas and Biofuels Institute (IBP)	Institute of Electrical and Electronics Engineers Oceanic and Engineering Society (IEEE-OES)

The IEEE OES Thirteenth Currents, Waves, and Turbulence (CWTM) Workshop

Weimin Huang and Mal Heron, CWTM Technical Program Co-chairs

The IEEE OES Thirteenth Current, Wave and Turbulence Measurement (CWTM) Workshop was successfully hosted at the Coastal Studies Institute (CSI, see Fig. 1), East Carolina University, Wanchese, NC, USA, during 17–20 March 2024. The CWTM Workshop is a four-yearly international workshop organized by the CWTMA Technology Committee, and it provides the ocean community with a great forum for technical information exchange and to promote coordination among those interested in measuring current, waves and turbulence, and their applications. This has been a very successful series with technical presentations, an integrated industry exhibition and papers archived in IEEE Xplore. The 12th CWTM Workshop was held on 10–13 March, 2019, in San Diego. For various reasons, including the COVID-19 pandemic, the most recent one was delayed by one year. This workshop consists of eight regular sessions, one panel session and one exhibitor presentation session. 47 registered for the workshop.

The atmosphere became lively with the Icebreaker reception at the Pioneer Theatre in Manteo where old friends and new faces of CWTM reunited, as shown in Fig. 2.

CWTM 2024 received 33 technical abstracts and 29 of them were scheduled into eight regular sessions focusing on five

themes (currents, waves, turbulence, sensors and other CWTM topics). Each presentation raised friendly and heated discussions (see Fig. 3). The Best Paper Award was based on the research novelty and quality in both abstract and presentation and went to the paper “Enhancing the Versatility of a 4-beam ADCP: Horizontal Use Case” authored by Lorraine Heilman, Robert Heitsenrether, Shaena Rausch, Edward Roggenstein and Evan Price, and was accepted by Lorraine (see Fig. 4). Two honorable mention awards went to “Distributed acoustic sensing (DAS) of seafloor fiber optic cables enables meter-scale resolution of surface waves in the coastal ocean” (authors: Maddie Smith, Jim Thomson, Hannah Glover, Meagan Wengrove, Michael Baker, Rob Abbott, Jacob Davis, Seth Zippel, and Wenbo Wu) and “The Next Wave: Buoy Arrays for Deterministic Wave Prediction in Real-time” by Jim Thomson, Alex Fisher and Curtis Rusch.

The panel session was dedicated to the promotion of UN Decade of Ocean Science for Sustainable Development (UNDOSSD). The panelists included Michelle Barnett, Eric Gill, Mal Heron, Weimin Huang, and Jim Thomson (see the article “Decade of Ocean Science in the CWTM 2024 Workshop” in this newsletter for more information). IEEE OES



Figure 1. Group photo in front of the CSI building.



Figure 2. Icebreaker reception night at Pioneer Theatre.



Figure 3. Attendees enjoying keynote speech given by Michael Muglia.

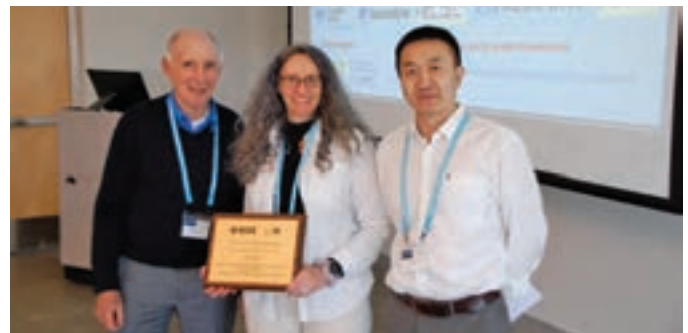

Figure 4. Lorraine Heilman receiving the Best CWTM Paper Award from the Technical Program Co-Chairs Mal Heron and Weimin Huang.

provided two Ocean Decade Scholarships to students and Post-docs to support their participation in CWTM 2024. Five students were selected as the finalists: Joe Craig (Memorial University), Jacob Davis (University of Washington), Brendan Henley (Rutgers University), Elias Marchetti (University of Plymouth), Zhiding Yang (Memorial University). Jacob and Brendan were awarded the scholarships. The recognition was announced at the workshop Gala in the North Carolina Aquarium Jennette's Pier (see Fig. 5).

CWTM 2024 promotes the merging of Academic, Engineering and Manufacturing aspects of Current, Waves and



Figure 5. Gala and Awards Dinner at Jennette's Pier.



Figure 6. Weimin Huang and Mal Heron at the OES booth.

Turbulence Measurement. Eight companies and IEEE OES (see Fig. 6) secured their exhibition booths, and they are also generous sponsors for the workshop. The Exhibitor Presentation session offered the sponsors/exhibitors the podium for 15 minutes to showcase their commercial products, test data or field operations and in-person discussions.

At the workshop, Mal Heron, with input from Sandy Williams and Hugh Roarty, gave a review of the history along with the statistics data of CWTM workshops. Although the number of attendees has fluctuated over the years, there has been consistent exhibitor support. During Mal's presentation, the audience also had an amusing discussion about the seven-legged octopus in the CWTM cartoon (as shown in Fig. 7). This important matter dates back to the 1st CMT Workshop in 1978.

Feedback from delegates and exhibitors indicated that CWTM 2024 was a resounding success. The next CWTM Workshop is pencilled in for 2027.

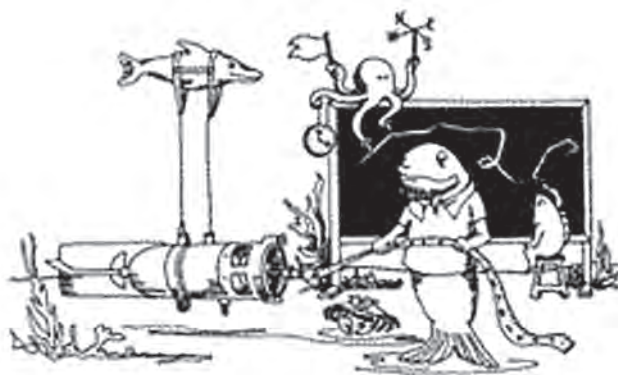

Figure 7. CWTM cartoon.

Exhibitors were:

- Teledyne Marine
- Helzel Messtechnik
- Pacific Gyre
- AXYS
- Nortek
- Flynn Technical Solutions
- Severn Marine Technologies
- IEEE-OES

The Singapore Autonomous Underwater Vehicle Challenge (SAUVC) 2024: The 9th Edition

Hari Vishnu, Yuen Min Too, Bharath Kalyan with Inputs from SAUVC Organizing Committee



SAUVC continued its successful streak this year with the 9th edition organized during 5–8 April 2024. This year's event achieved a new milestone in terms of team registration and participation, solidifying its status as the largest SAUVC to date. Endorsed by the United Nations Decade of Ocean Sciences, this edition underscored the event's alignment with the overarching goals of this global initiative, particularly addressing five out of its ten challenges. This endorsement also highlights the significant role played by IEEE OES within the framework of the Decade.

Notably, this edition held particular significance as it coincided with and was complemented by other OES events occurring in Singapore, namely the OES Summer School and the OCEANS 2024 Singapore conference, all within a week's timeframe. This convergence provided an invaluable opportunity for student teams to engage in hands-on learning through the challenge while also benefiting from tutorial-style education at the school, technical sessions, panel discussions at the conference, and interactions with the oceanic engineering community at large. Furthermore, participants could explore potential networking and career opportunities offered by OES programs such as CNET (Career and Networking Tours) at OCEANS.

This plan to synergize the events worked out successfully. Up to 80% of the summer school attendees was comprised of SAUVC team students who stayed back for the school, and there was some cross-participation across the events.

SAUVC in Numbers

This year saw: 79 teams registered for the event. These teams had to prequalify for participation by submitting a video of their AUV swimming underwater, with a requirement that the video should show it swimming for at least 15 seconds and demonstrating their AUV's depth control.

- 72 teams participated by submitting videos of their AUVs as part of pre-qualification requirements.
- 43 teams were selected from the submitted videos to attend the event in Singapore. There was a clear jump in the quality of team videos this year as compared to previous years, and

the judging team had a hard time shortlisting the teams, and strict quality criteria were used for filtering.

- 37 of the selected teams made it into the event. Some teams could not make it due to non-receipt of a travel-visa on time, or technical or financial issues. This is a phenomenon observed in most events, as students in the region (especially South Asia) often develop their AUVs on tight budgets and do not necessarily find the funds to travel so far for the event. Nevertheless, despite the travel, visa and funding issues faced



Teams setting up in the Singapore Polytechnic hall and interacting with the organizers, and SAUVC goodies!



Students attending the initial safety, logistics and technical briefings.

in the post-Covid era, it is impressive that so many teams made it and were able to participate.

- 320 student participants made it to the event in total, from
- 12 countries (India, Singapore, Indonesia, Malaysia, Turkey, Russia, Taiwan, Hong Kong, Saudi Arabia, Sri Lanka, Japan and Bangladesh, in decreasing order of participants). Notably, we had the first ever team from the middle East (Saudi Arabia) participating at the event, and the second-ever team from Bangladesh. Needless to say, both teams were elated to be here!
- 1 High-school team (from Alana Science High school, Turkey) performed very well at the competition, and the fact that they achieved this at an early stage in their education made it even more exciting.
- The representation of teams from across Asia was yet again extensive, and shows the value that SAUVC brings to this region.

The Challenge

SAUVC 2024 introduced two additional challenges this year as compared to previous year:

- **An underwater communication** task, to encourage teams to think about this important technological problem that is necessary for boosting ocean exploration, and
- A bonus round in the TCOMS Deep Ocean Basin facility in NUS, where teams had to deploy their vehicles in **waves and currents** generated in the facility, and pass through a gate.

The remaining tasks in this edition mirrored those of the previous one, following a two-tiered structure comprising a qualification round and a final round. To secure qualification, the AUV had to navigate from the designated starting line through the qualification gate without surfacing, contacting the bottom or walls, or the gate itself. The top 21 teams, achieving the swiftest times in the qualification round, progressed to the final round. During this stage, AUVs garnered points by executing a range of challenges designed to assess their abilities in acoustic and visual navigation, positioning, actuation, communication, and robotic manipulation. The ensuing table outlines the various functional capabilities under examination and their corresponding tasks.

No.	Task	Aspect of operation
1.	Passing through a gate, avoiding red flare	Navigation, Obstacle avoidance
2.	Locating a particular bucket amongst 4 options, and dropping a ball into it	Target acquisition and manipulation, Acoustic/Visual localization
3.	Moving out of the bucket arena, returning and reacquiring the ball dropped.	Target reacquisition and manipulation
4.	Bumping against a flare holding a ball to drop it, in a particular order	Underwater communication and Visual Localization
5.	Passing through a gate in TCOMs facility	Navigation in waves and currents (more realistic environment)
6.	Resurfacing at the end of the run	Controls

A red flare would be placed in front of the gate in the first task, which the teams were required to avoid, and hitting the red flare would incur the team's run ending immediately. This was to make sure the tasks were more challenging this year, thus progressively upgrading the challenge.



AUVs being debugged and deployed at the poolside, in the hot sun!

Each task carried a certain number of points, depending on the challenge and the difficulty involved in performing it. There was also a timing bonus, and a bonus associated with weight and dimensions of the AUVs. Apart from this, the tasks were made more challenging through randomization of the position of the buckets, flare and gate and its orientation. A complete description of the tasks, static judging criteria and award of points are covered in the competition rule book available at <https://sauvc.github.io/rulebook/>.



Judges (Venu, Hari, Bharath, Rajat and Mandar) interacting with teams during the technical walkabout for judging the Innovation award and Engineering Quality award.



Some cool AUV designs.

SAUVC 2024 Award Winners

A notable improvement in this edition was that 21 teams qualified into the finals, which is the highest number to date. Hence, the competition in the finals was stiff. The winner of SAUVC 2024 was a returning champion from a previous edition (2014), Bumblebee Autonomous systems from the National University of Singapore. The top 5 teams in the finals were as follows:

- 1) Bumblebee Autonomous systems, National University of Singapore
- 2) Team Abyss from Bannari Amman Institute of Technology, India
- 3) Mecatron from Nanyang Technological University, Singapore
- 4) Team Hydronautics from Bauman Moscow State Technical University, Russia
- 5) Team Alesta from Alana Science high school, Turkey.

In addition to the top 3 finalists, we also awarded the following:

- **IEEE OES “innovation” award**, which was constituted in 2019. This was judged by a technical panel consisting of 5 members. Innovation was defined as anything that is new/different and intentionally implemented for a specific stated purpose in SAUVC, with practically shown application. Based on the above criteria, the team Hydronautics from Bauman Moscow State Technical University was awarded the OES “most innovative engineering” award.
- **IEEE OES “Engineering quality” award**, from the Singapore chapter. The award was for the most sound and robust engineering design, and was awarded to Team Pioneer from City University, Hong Kong.
- **Fastest team award**, for the team that was fastest in the qualifier round. The team Alesta from Alana High School, Turkey, was awarded this prize, and it was also an encouragement for the young team. The award included two vouchers to attend the Breaking the Surface 2024 conference to be held in Croatia, allowing the teams to further their marine robotics training.

The bonus round was a specially celebrated feature of SAUVC 2024. It was conducted in TCOMS in the presence of

waves and currents generated in the ocean facility artificially. It gave the top 5 teams in the finals a chance to try their vehicle in more challenging environments involving waves and currents. Though many of the teams prepared their vehicles, and some teams managed to get very close to the gate (but missed it due to technical issues, eg., <https://fb.watch/r11s-IKoFo/>), only team Bumblebee from National University of Singapore managed to cross the gate in the bonus round with a superb performance from their vehicle (video here: <https://fb.watch/r11nY3-EtR/>). This was managed in the very last run of the vehicle just before time ran out, providing some nail-biting moments and drama to the round. The competition in TCOMS also provided an opportunity for other student teams to visit the state-of-the-art facility and learn more about ocean-simulation infrastructure, thus adding an educational element to it.



First prize winner and bonus round winner from Bumblebee, National University of Singapore being given the award by SP Deputy Director Goh Say Seng, and TCOMS CEO Chan Eng Soon.



The participants of the bonus round with the organizers.



First runner-up team from Bannari Amman Institute of Technology, India.



Winners of the IEEE OES Innovation award from Bauman state technical university, Russia, and the Engineering Quality award from City University of Hong Kong, being given the award by William Kirkwood.



Second-runner up from Team Mecatron, NTU, Singapore, being awarded by Marcus Tepaske from ONRG.



Winners of the fastest team award from Alana Science High school, Turkey, being given the award by the IEEE OES Singapore chapter chair Bharath Kalyan.

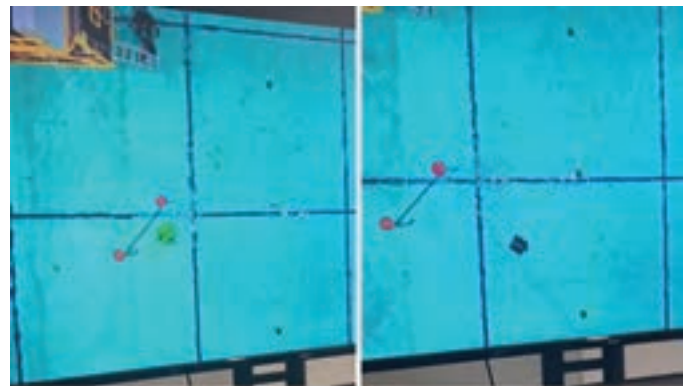

Team Bumblebee AUV (top and bottom) crossing the gate in bonus round, and Team Mecatron (NTU) getting very very close to it!

Gala Dinner, Award Ceremony and Panel Discussion

The event culminated with a gala dinner on April 8th, where the prize announcements took place. This occasion not only

provided teams with an opportunity to celebrate their achievements but also facilitated a relaxed networking atmosphere where they could engage with one another and with organizers from the underwater engineering community, spanning academia, industry, and defense sectors. The ceremony was hosted at Ngee Ann Polytechnic, creating a spirited and dynamic evening that included the distribution of participation certificates and the announcement of winners, sparking moments of joy and celebration. Following this, participants engaged in extensive discussions that stretched late into the night.

Furthermore, the event featured a panel discussion on the Ocean Decade, titled “ Navigating the Blue Frontier: Innovations in Ocean Technologies and Autonomous Systems for addressing Ocean Decade Challenges,” featuring notable figures from the marine robotics and education sectors. This panel discussion will be elaborated upon in a separate article within this edition of the Beacon. Additionally, a video showcasing Schmidt Ocean Institute (SOI)’s research vessel Falkor Too and the OES Berths of Opportunity was presented. In addition to students and panelists representing various academic and industry entities such as SUT, Subnero, Fugro, National University of Singapore, and Singapore Polytechnic, notable attendees included the Deputy Director of Singapore Polytechnic and the CEO of TCOMS Singapore.



AUVs being deployed at the poolside, and some moments of joyous celebrations.

Event Publicity and Social Outreach

As in previous events, this event has been well covered on social media. The event was also publicized via the UN Ocean Decade’s ECOP programme’s, and IEEE Singapore section’s social media portal (e.g., <https://www.facebook.com/photo/?fbid=395089736612811&set=a.123771213744666> and <https://www.facebook.com/photo/?fbid=833157275505912&set=pcb.833157315505908>). It was put up on the UN Ocean Decade’s page as well. The event will be reported in the ECOP programme’s newsletter as well, and in this sense, we established a good synergy between our event and the ECOP programme.

Our Facebook and Instagram handles showed a reach of 31,500 over the last year, of which 23,500 was over March to April 2024 alone. There were 1,200 content impressions and 1,200 content interactions over the last month. Instagram saw 9,052 accounts reached in the last 3 months alone, and 2,090 accounts who engaged with our profile. The posts reached followers mainly from South Asia (Bangladesh, Pakistan, Sri Lanka and India), Indonesia, Turkey, U.S., and Singapore.



Summary of social media statistics for the event.

Sponsorship

OES has always been a regular supporter of SAUVC in terms of sponsorship. Additionally, SAUVC 2024 was sponsored by Office of Naval Research Global (ONRG), Schmidt Ocean Institute, Sonardyne, Technology Center for Offshore and Marine Singapore (TCOMS), Society for Underwater technology, BlueRobotics and Breaking the Surface 2024. SAUVC is run solely on sponsorship, and we would like to sincerely thank all our sponsors for their support.



Sponsors of SAUVC 2024.

Concluding Remarks

SAUVC has been successfully organized in nine consecutive editions over the past decade, establishing itself as possibly the largest and most prominent autonomous underwater vehicle competition for students in Asia and Europe. It has garnered considerable interest within the student robotics community and has had a tangible impact on student learning and ocean education outcomes.

The committee has noted the emergence of at least three marine robotics-based startups that originated from teams participating in SAUVC. These include BeeX in Singapore,

which stemmed from the Bumblebee team, BRACU originating from the Bangladesh-based BRACU Duburi team, and another startup based on Team Tiburon from the National Institute of Technology Rourkela, India. The latter team even gained exposure on the reality TV show “Shark Tank India,” where they garnered significant investor interest, attributing their success in part to their participation in SAUVC!

Previous SAUVC winners, such as Bumblebee and BRACU, have gone on to achieve success in other marine robotics competitions held in the USA, including RoboSub, showcasing how the learning experience at SAUVC has fostered the growth of these teams. Several teams in the current edition exhibited noticeable growth in both their AUVs and team structure, exemplified by Team Abyss from India, who were runners-up in this edition after securing the second runner-up position in SAUVC 2022.

SAUVC 2024 has established fruitful synergy with other IEEE OES events, including OCEANS 2024, the inaugural Summer School, CNET, and Breaking the Surface 2024. Various OES initiatives were also highlighted at the SAUVC gala dinner, including Berths of Opportunity and the AUV Symposium.

By not imposing a blanket registration fee for participation, SAUVC continues to attract significant participation each year. This no-registration fee policy aims to encourage novice teams to compete, with IEEE OES membership drives conducted as part of the registration process. The substantial representation in terms of participating countries, number of students, and diversity is deemed encouraging. Additionally, SAUVC prioritizes educational outreach, providing teams not only with a hands-on competition experience but also with valuable interactions with committee members and marine robotics experts who offer mentoring and guidance.

IEEE-OES Summer School 2024 ... A Roaring Success!

Shyam Madhusudhana, VP for Technical Activities



In the bustling metropolis of Singapore, amidst the backdrop of the much-anticipated Singapore OCEANS conference, the inaugural Oceanic Engineering Summer School made waves as a beacon of learning and collaboration. Held from April 13th to 14th, 2024, at the elegant Grand Copthorne Waterfront hotel, this pilot event drew in 43 eager participants, primarily students, and a sprinkling of early-career profession-

als, all united by their passion for learning and exploration of the oceanic engineering discipline. Under the overarching theme of *Observing our Ocean*, the Summer School’s agenda was meticulously crafted to provide a comprehensive overview of cutting-edge techniques and advancements in the field of oceanic engineering.

The event kicked off with an icebreaker social mixer on the evening of April 12th, setting the stage for two days filled with enriching lectures, hands-on sessions, and networking opportunities. As attendees mingled over refreshments and exchanged insights, an atmosphere of anticipation filled the air, foreshadowing the enlightening journey that lay ahead. Day one commenced with a series of four technical lectures, each delving into different facets of ocean observation, complemented by a hands-on session. Day two unfolded with equal fervor, featuring three more technical lectures and two professional development sessions. OES leaders Malcolm Heron (Adjunct Professor, James Cook University) and Elizabeth Creed (VP of Professional Activities, IEEE-OES) ran the professional development sessions, offering insights into career development and imparting invaluable wisdom on navigating the evolving landscape of oceanic engineering.

The breadth of technical topics covered during the Summer School was truly impressive. A highlight of the event was the



Participants, faculty, and supporting volunteers at IEEE-OES Summer School 2024.



Participants and faculty enjoying sumptuous dinner following the evening's icebreaker social.



Prof. Weimin Huang kicking-off the School with the first of the technical lectures.



Supporting volunteers from the Singapore OES Chapter: (left-to-right) Kexin, Luyuan, Hari, [yours truly], Bharath, and Rajat. Missing in the photo are Shuangshuang and Venu.

engaging demonstration on developing underwater networks using UnetStack, a powerful tool for underwater communication protocols, which sparked lively discussions and fueled attendees' enthusiasm to explore the possibilities of this innovative technology further. Many thanks to our multinational faculty for volunteering their invaluable time and energy in offering (the below) captivating lectures.

Lecture topics

Ocean remote sensing with ground-based radars: HF and X-band

Prof. Weimin Huang
Memorial University, Canada

Non-destructive ocean sampling using laser Raman techniques

Dr. William Kirkwood
MBARI, USA

Passive acoustic monitoring in marine environments

Dr. Shyam Madhusudhana
Curtin Mauritius, Mauritius

Developing underwater networks using UnetStack

Chinmay Pendharkar
Subnero, Singapore

Satellite-based ocean remote sensing

Prof. Maurizio Migliaccio
Università degli Studi di Napoli Parthenope, Italy

Oceanographic mooring design

Dr. Andreas Marouchos
CSIRO, Australia

Next-wave ocean sensing and monitoring and the role of AI in ocean resource and ecosystem management

Prof. John R. Potter
Norwegian University of Science and Technology, Norway

The success of the Summer School was palpable, as participants left with newfound knowledge, inspiration, and a strengthened sense of community. Their positive feedback echoed the sentiment that the event had exceeded expectations and provided valuable insights that would shape their future endeavors in the field.

The success, however, would not have been possible without the tireless contributions of some of the members of the Singapore OES Chapter. Venugopalan Pallayil, Hari Vishnu, and Bharath Kalyan, who were already too busy organizing the OCEANS conference, offered key contributions in organizing the School as well. While I thank them for their invaluable support, I also thank Kexin Li, Luyuan Peng, and Shuangshuang Wu for groundwork during the days of the School, and Rajat Mishra for being our official photographer.

How would you rate the overall organization of the Summer School?



How would you rate the networking opportunities provided during the Summer School?

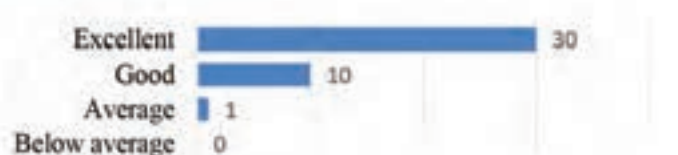

How likely are you to recommend the Summer School to a colleague or friend?



Aggregated feedback from 41 respondents who attended the Summer School.



The Chair of the IEEE-OES Summer School program, yours truly, distributing certificates of appreciation to the faculty: (left-to-right) Weimin Huang, Bill Kirkwood, Mal Heron, Maurizio Migliaccio, Andreas Marouchos, Liz Creed, and John Potter.

As we reflect on the inaugural IEEE-OES Summer School, we celebrate not only the knowledge gained but also the connections forged and the spirit of collaboration that continues to propel our collective journey of exploration and discovery in the vast expanse of our oceans.

Looking ahead, plans are already underway for the next iteration of the Summer School, slated to be held alongside the

2025 Brest OCEANS conference. With anticipation building and enthusiasm abound, organizers are poised to deliver yet another exceptional event that promises to enrich and empower the wider oceanic engineering community.

Stay tuned for updates on the upcoming Summer School and join us as we embark on another exciting chapter in our quest to unlock the mysteries of the deep blue sea.

IEEE SusTech 2024 Report

Edward Perkins, Chair, IEEE SusTech 2024



The 11th IEEE Conference on Technologies for Sustainability (SusTech 2024) was held in hybrid format on April 14–17, 2024, in Portland, Oregon. See <https://iee.org/sustech>

The SusTech 2024 Program featured Keynotes, Panels, Papers, Student Posters, and a Sustainability Forum. See <http://iee-sustech.org/> for details on the program and events.

The SusTech conference is designed to explore development that meets the needs of the present without compromising the ability of future generations to meet their own needs. It brings together scientists, engineers, technologists and scholars from multiple disciplines to hold a dialogue on environmental issues and collaborate on ideas to develop and utilize innovative tools and intelligent systems to address the need for Sustainable Infrastructure. Attendees will learn about the emerging technologies, latest tools, and proactive solutions to take their sustainability programs to the next level. Papers are solicited from industry, government, and academia (including collegiate students) covering relevant research, technologies, methodologies, tools and case studies. Conference content that meets IEEE quality review standards and format will be submitted for inclusion into the IEEE Xplore Digital Library.

Sponsors: Included the IEEE Oregon, San Fernando Valley, Foothill, Orange County, and Coastal Los Angeles Sections, IEEE Region 6, IEEE-USA, IEEE Society on Social Implications of Technology (SSIT), and co-sponsored by the IEEE

Standards Association, and the IEEE Industry Applications Society (IAS), **Oceanic Engineering Society**, Power and Energy (PES) Society, Technology and Engineering Management Society (TEMS) and the IEEE Sensors Council.

For 2024 we partnered with the IEEE Future Directions Climate Initiative, aka the IEEE SusTech Initiative. The Initiative held a one-day workshop “on “Roadmap to Low Carbon Emission Building Materials and Architecture” on 14 April.

Not counting the Workshop, SusTech 2024 had 100 registered attendees plus 17 student poster contestants and 6 guests. As the conference was hybrid, this was broken down as: in person authors 24; in person attendees 37; virtual authors 30 and virtual attendees 7. U.S. Visa issues are a continuing problem hindering author in-person attendance.

SusTech 2024 featured a four-day program with workshop, poster contest, receptions, dinner, technical presentations, sustainability forum, keynotes and plenary talks and panels.

The technical conference featured over 60 paper presentations in 18 sessions on 15-16 April in these Thematic areas:

- Energy Efficiency (3)
- Renewable/Alternate Energy (2)
- Smart and Micro Grids (2)
- eWaste & Circular Economy
- IOT (2)
- ML Application
- Societal Implications (2)
- Sustainable Electronics (3)
- Sustainable Management
- Water

There were also five keynotes and three panels.

- **IEEE Climate Change Update**, Maike Luiken, IEEE Sus-Tech Initiative
- **Solar Trends**, Wei-Jen Lee, University of Texas at Arlington
- **Data Center Efficiency and Sustainability**, Eric Dahlen, Intel Data Center and AI Group
- **ReCell: Working to Advance Battery Recycling**, Eva Allen, Applied Materials Department, Argonne National Laboratory
- **A Vision for Mid-Century Sustainable Urban Transportation**, Tyler Folsom, University of Washington Bothell
- **Panel: Ethics, Energy and Environment**, organized by Gopal Tadepalli, IEEE SSIT and Susan Dickey
- **Panel: Electrifying Agriculture**, organized by Wendy Simons from the Oregon Department of Energy.
- **Panel: Novel Technologies for Sustainable Ocean Energy Generation**, organized by Bill Wilson, IEEE Oceanic Engineering Society

The **Sustainability Forum**, a unique one-day conference track on 17 April, focused on topics of interest to and presented by industry practitioners and technical professionals:

- **Electrification is a key strategy for decarbonizing all sectors of the U.S. economy**, Hellen Chen, Research Analyst in the Industry Program, American Council for an Energy-Efficient Economy (ACEEE)
- **Electrification and the Grid**, Ted Witham & Joe Cappeta, Eaton Corp.
- **Panel: Promising Heat Pump Developments: Perspectives from the Pacific Northwest**, organized by Stephanie Kruse, P.E., from the Oregon Department of Energy
- **Special Session: Hot Topics in Sustainability**, Maike Luiken, IEEE SusTech Initiative
- **Increasing Computing Energy Efficiency is Key Requirement for Sustainability**, Tina Kaarsberg, Acting Program Manager, Advanced Materials and Manufacturing Technologies Office (AMMTO), U.S. Department of Energy (DOE)
- **Efficient, Cost-Effective Polymeric Materials Design for Clean Energy and Biomedical Technologies via Biomass Valorization**, Shudipto Konika Dishari, Ross McCollum Associate Professor, Chemical and Biomolecular Engineering, University of Nebraska-Lincoln
- **Off-shore Wind Power Studies**, Dmitry Kosterev, BPA

We appreciate the support of OES in the conference. Bill Wilson, chair of the OES TC on Ocean Sustainable Energy Systems organized a panel on **Novel Technologies for Sustainable Ocean Energy Generation**.

The panel brought together leading experts, researchers, and innovators to explore groundbreaking advancements in the realm of offshore renewable energy. With the pressing need to mitigate climate change and reduce dependence on fossil fuels, offshore energy generation presents a promising avenue towards achieving sustainability goals. The panel aims to showcase emerging technologies and discuss their potential to revolutionize the offshore energy landscape while addressing environmental concerns.

Panelists (hybrid):

Dr. Peter F. Green, National Energy Research Laboratory (NREL)

Dr. Daniel Deng, Pacific Northwest National Laboratories

Dr. Landon Mackey, C-Power, Corvallis, OR

Andy Stough, Windlift, Durham, NC

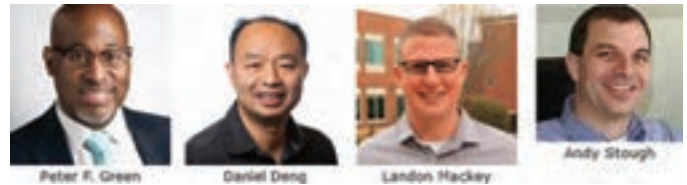

OES Panelists



In 2023, for the 10th Anniversary conference, Bill organized a panel on **Sustainable Ocean Energy Technology and Policy**, which focused on the various ways in which the ocean can be harnessed as a source of clean and sustainable energy, such as through the use of offshore wind, wave and tidal power. Panelists discussed the current state of technology in this field, as well as the potential for future growth and development. They also addressed the public policy and financial barriers to fully realize the potential of ocean energy, such as the high costs of building and maintaining ocean energy systems and the mitigating potential environmental impacts. The discussion provided a comprehensive overview of the state of the field and the opportunities and challenges that lie ahead.

We look forward to continuing the relationship with OES in future SusTech Conferences.



Opening Keynote.



Lunch.



Panel.
(Photos courtesy Ed Perkins).



IEEE Oceanic Engineering Society

IEEE OES AUV Symposium 2024

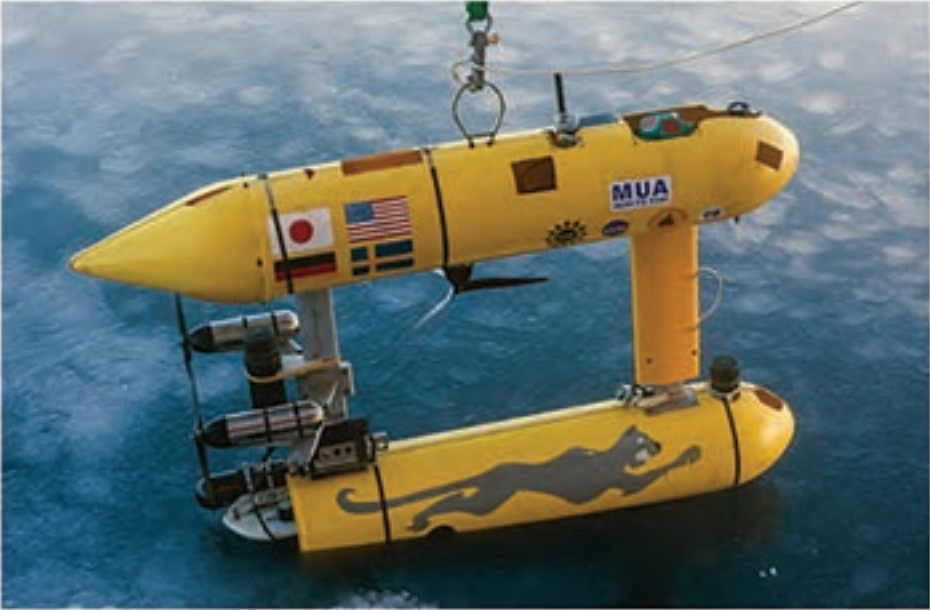

- Vehicle Design
- Vehicle Navigation
- Sensor Fusion
- Vehicle Control
- Vehicle Planning and Execution Control
- Multi Vehicle Systems
- Vehicle Applications
- Open Source Robotics

September 18th to 20th 2024

<https://auv2024.sites.northeastern.edu/>



5th Marine Imaging Workshop (#MIW24)



Monterey, CA
Oct 7-10, 2024
miw2024.org



Image: MBARI's Bioinspiration Lab

Underwater Technology 2025



2025 IEEE International Symposium on Underwater Technology

Date | March 2nd-5th, 2025
Venue | The Grand Hotel Taipei



ut2025.org



Abstract submission opens: June 14, 2024
Deadline for abstract submission: September 10, 2024
✉ secretariat@ut2025.org



IEEE Oceanic Engineering Society



A Blast from the Past! . . . You Gotta Love the Socials

Bob Wernli—Beacon Co-Editor-in-Chief and Photographer Stan Chamberlain

Well, one of the best aspects of the OCEANS conferences are the receptions, Galas and other social events. Mmmmmmm... we love our foods. Following are a few of our enjoyable times. There are many more to come.



OCEANS '22 Hampton Roads Gala.



OCEANS '19 Seattle Gala.



OCEANS '19 Marseille Gala.



OCEANS '18 Kobe Leadership Dinner.



OCEANS '14 Taipei Welcome Reception.



OCEANS '14 St. Johns Gala.



OCEANS '17 Anchorage Gala.

OCEANS 2024 Singapore—A Brief Review

Venugopalan Pallayil, General Co-Chair of OCEANS 2024 Singapore

Singapore hosted its second in-person OCEANS conference successfully during 15 to 18 April 2024. The conference was held at the Sands Expo Convention Centre, Marina Bay Sands, one of the top conference centers in Singapore.



The conference venue (left); the unique infinity pool on top of the conference center hotel was an attraction for many delegates.

Two ‘satellite events’ namely the Singapore AUV Challenge (SAUVC) and the Summer School added more vibrancy to the overall conference programme, which was stretched over two weeks. These two events provided an opportunity for some of the students to participate in all the actions leading to the conference and was an enriching experience for them as well as for the organizers. Separate reports on these two activities have been covered elsewhere in this Newsletter. One unique feature of OCEANS 2024 Singapore was that all the conference events were held at the same venue and spread around the same floor so that the delegates could move between technical sessions, poster sessions, plenaries, panel discussions and the exhibition freely and easily.

The Guest of honor for the conference was Mr. Desmond Lee, the Minister for National Development, Singapore. He spoke high about the need for organizing conferences like OCEANS in Singapore and the need of the hour is to understand how climate change and related issues will impact small islands like Singapore. The minister also formally opened the exhibition after his inaugural address. The opening speech by the Minister can be accessed here:

<https://www.mnd.gov.sg/newsroom/speeches/view/speech-by-minister-desmond-lee-at-the-oceans-2024-conference>

Mr. Lee also posted his comments on the conference on his social media outlets and following are the links to the same.

https://www.instagram.com/desmond.lee/p/C6D2YCePQv5/?img_index=1

<https://www.linkedin.com/posts/activity-7188119362917040128-838N/>

Local Organising Committee



The Local Organising Committee with Presidents of the two Societies.

General Co-Chair	Venugopalan Pallayil
General Co-Chair	Chia Chin Swee
Technical Chair	Mandar Chitre
Finance Chair	Koay Teong Beng
Exhibit Chair	Bharath Kalyan
Tutorial Chair	Hari Vishnu
Student Poster Competition Chair	Too Yuen Min
Local Arrangement Chair	Luyuan Peng
Exhibit Co-Chair	Phillip Thomas
Promotional Chair	Manu Ignatius
Webmaster Chair	Rajat Mishra

Zdenka Willis from Marine Technology Society and Ken Tekagi from IEEE Oceanic Engineering Society served as liaisons.



Minister with LOC members, honorary chair, Prof. Chan Eng Soon, Plenary speakers Dr. Rick Spinrad and Dr. Meghan Cronin, IEEE OES President Brandy Armstrong and MTS President Justin Manley at the Tropical Marine Science Institute Booth.

Participation

It is estimated that there were close to 950 attendees of which over 300 were trade visitors. The actual numbers are not available at the time of preparation of this article. There was representation from 44 countries among registered delegates. There were 45 paid exhibitor booths and complimentary booths of one each was provided to the two sponsoring societies and two future OCEANS organisers (Brest 2025 and Sanya 2026) respectively.

Technical Programme

The technical programme had all the usual OCEANS' flavours covering general topics of interest as well as topics that were of local interest. The programme was built around the conference theme “**Climate resilience, coastal protection and a sustainable Ocean.**” There were plenaries, panel discussions, student poster competition and general posters as well as tutorials organised as part of the technical programme. About 325 technical papers were presented over three days.

Tutorials

The tutorials were offered at a nominal cost to participants with full registration and with an extra cost to others. There were three tutorials held and all were reasonably well attended. Below table shows the tutorial topics and number of attendees.

Title of Tutorial and duration	Number of attendees
Detection of Underwater Acoustic Signals: Theory and Techniques (full day)	31
AUV Technologies and Application Basics (half day)	21
Data meets Model Predictive Control: from Classical MPC to an online adaptive direct data-driven navigation and control of autonomous vessels (half day)	25

Attendees were offered IEEE Continuing Education Units or CEU credits if they wish to.



One of the tutorial sessions in progress.

Plenaries

OCEANS 2024 Singapore showcased two plenaries immediately after the conference and exhibition opening. The first plenary on “Facing Climate Change” was delivered by Dr. Rick Spinrad, Under Secretary of Commerce for Oceans and Atmosphere & NOAA Administrator. The second plenary titled “The Big Ocean and Atmosphere Meet Up” was presented by Dr. Meghan Cronin, Oceanographer, NOAA Pacific Marine Environmental Laboratory Co-Chair, Observing Air-Sea Interactions Strategy (OASIS). During a short break between the two plenaries, Prof. Rene Garello, General Chair for OCEANS 2025 Brest, presented a promotional video on Brest OCEANS. There was no overlap between the technical sessions and the plenaries to ensure maximum attendance.



Dr Rick Spinrad giving his plenary ‘Facing the Climate Change’

Panel Discussions

In line with the conference theme, three panels were held under the IEEE OES Ocean Decade Initiative. All the panels were well attended and there was engaging discussions among the panelists and attendees, which went beyond the scheduled time. One of the panel discussions was on “Ocean Observing Platforms and Technologies for Ocean Decade: Perspectives and Prospects” where the panelists discussed some of emerging



Panel on ‘Ocean Observing Platforms and Technologies: Perspectives and Prospects.’

ocean observing autonomous platforms and technologies relevant to the UN Ocean Decade theme ‘the science we need for the oceans we want.’



Panel on ‘Shifting Mindsets, Overcoming Barriers.’

Another panel titled “UN Ocean Decade: Shifting Mindsets, Overcoming Barriers” identified and discussed the barriers that impede progress toward the UN Ocean Decade goals and to explore strategies for fostering a shift in mindset among professionals working in ocean-related fields. You can read the report on the panel in this issue too. The third panel discussion was on the theme “The integration of Marine Science and Oceanic Engineering Communities in South-East Asia.” This session was aimed at bringing together marine scientists, policy makers and ocean engineers based in South-East Asia (SEA) to join hands to discuss what would be appropriate research collaboration platforms that can spur better collaboration in the region. IEEE Oceanic Engineering Society supported the last two of the three panel discussions through its Ocean Decade Initiative Programme.



Panellists from panel on ‘The integration of Marine Science and Oceanic Engineering Communities in South-East Asia.’

Student Poster Competition (SPC) and General Posters (GP)

Over 70 submissions were received under the SPC category with 40 odd General Poster submissions. After a two-stage review, 17 papers were selected for SPC and 16 of them turned up. The SPC was supported by Office of Naval Research Global who provided a grant to cover both the travel and regis-



SPC certificate distribution and award ceremony were held during the gala. SPC participants with judges.

tration fee for the participating students. Schmidt Ocean Institute sponsored the prize money for the winners. Details of SPC is provided in a separate report in this newsletter.

Social Events

Welcome Reception

Over 400 delegates attended the welcome reception held at the foyer of Marina Bay Sands Convention Centre on 15 April 2024. It was a free and easy event with ample food and beverages served. Bhangra, a type of traditional folk dance of Punjab area of the Indian subcontinent was the highlight of the event, which got the participants excited and engaged.



Welcome Reception at the venue foyer.



Bhangra Dance, and Indian cultural dance being performed during reception. Some of the delegates joined the fun.



The welcome reception was well-attended.

Exhibitor Reception

The exhibitor reception was held on 16 April at the exhibit hall with sumptuous food and beverages. This event was attended by over 450 delegates.



Delegates at the Exhibitor Reception.

Gala Dinner

The Gala dinner was held on 17 April at the venue Orchid ball room and over 500 delegates attended the dinner. The sit-in dinner was more convenient when compared to a buffet type where delegates have to queue for a long time before they can get food for themselves. The sit-in style also promoted more interactions with the delegates from different parts of the world. The dinner featured local 5-course Chinese culinary. There was a simple cultural programme featuring Chinese orchestra. Unlike in other OCEANS, the SPC award ceremony was also held during the Gala Dinner and this ensured the students got the attention they needed at such ceremonies.



A view of the gala dinner setup at the Orchid Ballroom.



Chinese Orchestra in progress during Gala.

Dr. Victor Dyomin, the First Vice-Rector, National Research Tomsk State University, sent us the following compliment:

“Dear Venu, it was my pleasure to participate in the OCEANS-2024 and to see you again. Everything was excellent! I know it was a hard job so now you have time to relax.”

Exhibition



Guest of Honor Minister Desmond Lee cutting the ribbon and opening the exhibition for delegates and visitors.

The Guest of Honour, Minister Desmond Lee, opened the exhibition with a ribbon cutting ceremony. He took a tour of the various exhibits and held brief discussions with some of the exhibitors. There were 45 companies showcasing their products during the conference. Both Japan and Canada had setup their respective country pavilions. EvoLogics Pte Ltd was our silver sponsor while Kongsberg Discovery Pte Ltd was the bronze sponsor. Dr. Martin Gutowski, Vice-President of Sales and Marketing of Kongsberg Discovery, has this to say,

“Hi Venu, thanks to you and your team for putting up such a good event. It was very well organised and gave us the opportunity to catch-up with stakeholders in the community. I got a lot of positive feedback. I believe you resented Singapore and the local industry and maritime community well.”



Minister interacting with the exhibitors.

Ancillary events

Like in any other OCEANS, OCEANS 2024 Singapore also hosted many ancillary events. These events showcased the conference commitment to engage different communities that are central to both societies. The events facilitate networking and panel discussions, opportunities on themes and topics of interest to different groups representing students, Young Professionals and Women in Engineering. Details of some of these events are covered in separate reports elsewhere in this newsletter by the persons in charge of organizing the event.

The Student Mixer was jointly organized by IEEE OES and MTS. Over 50 students attended the event. Food and non-alcoholic beverages were served. This event was held immediately after the Welcome Reception and also at the venue hotel. The Women in Engineering (WIE) Breakfast Panel was organized by the IEEE OES on 16 April and the Young Professional (YP) panel was held over lunch jointly by the two Societies. IEEE OES also organized 'Member's Meet,' a very interactive fun-filled networking event for its members. Participants opined that this was one of the best networking events they have attended.

Technical Tours

Technical tours were organized as part of the conference to visit three local scientific establishments of interest.

- 1) Technology Centre for Offshore and Marine, Singapore (TCOMS) is a world class next generation Deepwater Ocean Basin research facility, which is equipped with advanced wave and current generation systems to simulate challenging ocean environments that marine platforms and ships operate in.



Singapore OES Chapter Networking Event.



Visit to the SJINML Research Facility.

To learn more about the \$107m giant pool – Singapore’s first Deep Sea Ocean visit <https://www.tcoms.sg>

- 2) St. Johns Island National Marine Laboratory (SJINML) is Singapore’s only offshore marine research facility managed by the National University of Singapore (NUS). Strategically located near to the Sister’s Island Marine Park, the first designated Marine Park in Singapore, the facility is built as a National Research Infrastructure. 30min by boat from the mainland, this facility hosts marine research labs, an aquaria and other supporting facilities including a small research vessel. Read more on this facility here: <https://sjinml.nus.edu.sg>

- 3) Singapore New Water Plants (SNWP) produces 12% of Singapore’s current water needs. Integrated with Changi water Reclamation Plant, the Sembcorp NEWater Plant is one of the only large-scale water recycling plants in the world to be housed on top of a water reclamation plant. You can find details of this facility here: <https://www.siww.com.sg/spotlight-2023/programme/technical-site-visits/changi-water-reclamation-plant-n-semcorp-newwater-plant>

On the last day of the conference, IEEE OES Singapore Chapter organized a barbecue networking event sponsored by Subnero Pte Ltd., Singapore. The event took place at the premises of Acoustic Research Laboratory, National University of Singapore. This fun filled evening provided much needed unwinding for the LOC as well.

Overall, the OCEANS 2024 Singapore was a well-attended and well-organised conference. The feedback received from both attendees and exhibitors has so far been very positive. Before I close this report, on behalf of the LOC, I would like to thank all the participants, exhibitors, and patrons for supporting OCEANS 2024 Singapore. Special thanks to our patron, Singapore Tourism Board (STB), who has been with us in this journey since the conference bidding process began. It is now time to look forward to our next big event OCEANS 2024 Halifax. See you all there.

IEEE OES and MTS Co-Host OCEANS Singapore Student Mixer

Elizabeth L. Creed, Vice President for Professional Activities

The OCEANS Singapore edition of the Student Mixer was held immediately after the Ice Breaker on Monday evening. In existence since 2010, and co-hosted by the IEEE OES and the MTS, this event was instituted as a way for students attending the OCEANS Conference to meet their fellow student attendees as well as the leadership from both societies. To get the mixing started, the students were initially divided into groups of 5-6 people who did not know each other and spent 10 minutes intro-

ducing themselves. After 3 or 4 iterations of introductions, the students began mingling on their own. Based upon the number of students attending (~85), the number of animated conversations going on, and the large number still present when the convention center personnel gently informed all of us that the event actually ended 15 minutes ago, the mixer was a success.

The next edition of the Student Mixer will be held at OCEANS 2024 Halifax in September. We hope to see you there.

OES Hosts a Member Reception at OCEANS Singapore

Elizabeth L. Creed, Vice President for Professional Activities

The OES hosted a reception for its members attending the Singapore OCEANS Conference. More than eighty members participated in the event at the Grand Copthorne Hotel–Waterfront on Tuesday, 15 April, 2024. The evening went quickly with members catching up with old friends as well as making new acquaintances. In addition, the OES took the opportunity to present the 2023 OES Distinguished Service

Award to Fausto Ferreira and the 2023 OES Distinguished Technical Achievement Award to Gabriele Ferri as neither recipient was able to attend the awards ceremony held during OCEANS Gulf Coast in September 2023. Congratulations to both!

The evening came to a close with a group picture (see below).



*Awardees Fausto Ferreira and Gabriele Ferri.
(Photo by Rajat Mishra).*



OES Member Reception. (Photo by Rajat Mishra).

If you are attending OCEANS Halifax this coming September, please plan to attend the OES Member Reception, tentatively scheduled for Tuesday evening, after the Exhibitor Reception.

The Student Poster Competition at OCEANS 2024 Singapore

Dr. Yuen Min Too, Singapore LOC Student Poster Competition Chair

Dr. Shyam Madhusudhana, IEEE—OES Student Poster Competition Chair

The OCEANS 2024 Singapore conference, held from April 14 to 18, 2024, featured a flagship event—the Student Poster Competition (SPC), which served as a platform for showcasing cutting-edge research by students in ocean engineering and marine technology. This year, the OCEANS Singapore SPC received 66 abstract submissions. Following a meticulous two-stage review process, 16 exceptional posters emerged as finalists for the competition. The selected candidates received comprehensive financial backing, encompassing coverage for their conference registration fees, as well as expenses for travel and accom-

modation, all thanks to the generous sponsorship of the Office of Naval Research Global (ONR-G). The Schmidt Ocean Institute has graciously continued its contribution of prize money for OCEANS Singapore SPC. We also extend our gratitude to our sponsoring societies, the Oceanic Engineering Society (OES) and the Marine Technology Society (MTS), for their unwavering support, without which the success of the SPC would not be possible.

At the conference, all finalists participated in the SPC, showcasing their work to a captivated audience during well-attended



Presenting certificates of participation to the finalists.



Awarding certificates of achievement to the winners.

poster sessions. The students' energy and enthusiasm were contagious, making the conference a truly enriching experience for all. We express our deepest appreciation to the esteemed panel of six judges who generously volunteered their time. The judges provided valuable feedback by interacting directly with the participants and scoring their posters. The OCEANS Singapore SPC culminated with a prestigious awards ceremony held during the conference's Gala dinner. Local Organizing Committee's SPC Chair, Yuen Min Too, and IEEE OES SPC Chair, Shyam Madhusudhana, presented participation certificates and winning prizes.

Below is the list of participants, including prize winners, along with their affiliations, poster titles, and abstracts:

First prize (Norman Miller Award) (Certificate and \$ 3000)

Jonathan Lephuc, Texas A&M University, USA, *Design and Testing of an Amphibious Cycloidal Propeller Unmanned Underwater Vehicle*



Abstract—This paper covers the design, development, and testing of a 43 kg (95 lb) amphibious cycloidal propeller unmanned underwater vehicle (Cyclo-UUV) that utilizes a combination of cycloidal propellers (or cyclo-propellers), screw propellers, and tank treads for operations on land and underwater. The use of cyclo-propellers allows for 360° thrust vectoring for more robust dynamic controllability compared to UUVs with conventional screw propellers. Four cyclo-propellers are used to control the Cyclo-UUV while underwater and can be retracted into a set of four wheels to allow for transition-

ing between underwater and land locomotion. Control of the vehicle underwater is achieved by modulating the cyclo-propeller rotational speed and blade pitch phase angle, allowing for control over the magnitude and direction of the thrust vector of each cyclopropeller to enable surge, heave, roll, pitch, and yaw motions. These changes to pitch phase angle are controlled by rotary servos which receive commands via an on-board autopilot with an inertial measurement unit (IMU) that measures the vehicle's attitude and stabilizes the vehicle using a proportional-integral-derivative (PID) controller. Systematic testing of the Cyclo-UUV was conducted to verify its mechanical operation, trim the cyclopropellers for forward motion, tune the PID controller gain values for good response and disturbance rejection, and evaluate the vehicle's performance in both calm water and in the presence of breaking waves similar to those found in the surf zone. The Cyclo-UUV has demonstrated a high degree of maneuverability and controllability in forward motion underwater, as well as the unique capability of performing transitions between land and underwater through breaking waves.

Second prize (Certificate and \$ 2000)

Sehwa Chun, The University of Tokyo, Japan, *3D Detection and Tracking of Mooring Lines of Floating Offshore Wind Turbines by Autonomous Underwater Vehicle*

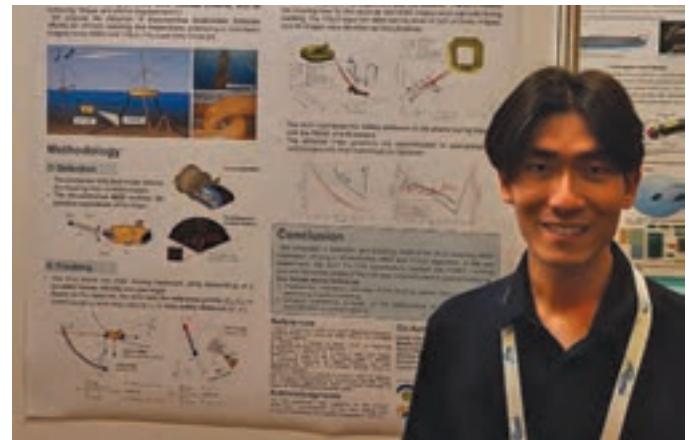

Abstract—This paper introduces an innovative method for inspecting mooring lines of Floating Offshore Wind Turbines (FOWTs) using an Autonomous Underwater Vehicle (AUV) equipped with a tilt-controlled Multibeam Imaging Sonar (MBS). The approach aims to enable the AUV to accurately estimate the position of the mooring lines and safely track them. This method overcomes the limitations in traditional

inspection techniques and lays the groundwork for the integration of additional methods for more detailed inspections.

With the tilt angle of the MBS and a pre-trained YOLO model, the AUV estimates 3D positions of the mooring chains with sonar imagery. The tracking method is designed to maintain safe distance to the chains by dynamically adjusting surge and sway velocities, based on the real-time detections. Through continuous tracking, the AUV is capable of reconstructing the whole structure of the mooring line with its position data estimated by dead-reckoning.

The proposed method was tested using a hovering type AUV, Tri-TON, in a sea trial at an FOWT, Hibiki, in Kitakyushu, Japan. The experiment validated the AUV's effectiveness in tracking the mooring lines for 343 seconds and successfully reconstructing their entire structure. Moreover, the experimental results indicate a need for further tasks, particularly in enhancing the AUV's positional accuracy and in conducting a thorough analysis of the chains' physical characteristics to facilitate a more comprehensive evaluation of their condition.

Third prize (Certificate and \$ 1000)

Shashank Swaminathan, Massachusetts Institute of Technology, USA, *A Distributed "Any-Communication" Task Allocation Approach to Information-based Planning Underwater*

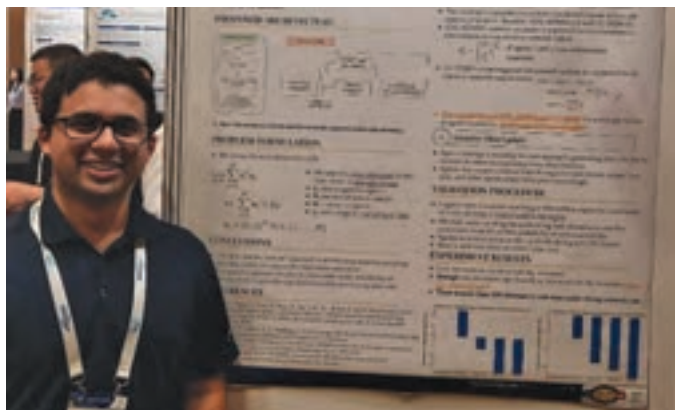

Abstract—Autonomous ocean monitoring poses a unique challenge due to the dynamic and restrictive underwater environment. Distributed adaptive sampling can address many of the challenges of a large and evolving system; however, it typically requires strong assumptions on the communicability of the agents. This paper's goal is to propose a novel "Any-Communication" approach to performing distributed adaptive sampling under limiting communication conditions, including the underwater space, through using a task allocation approach to information-based planning and a communication-robust distributed solver. The approach is verified against multiple randomized simulated trials, and the resultant improvement in optimality is compared against a naive distributed approach. The trials indicate that when under a simple linear cost agent model, the approach can provide up to 30% reduction in agent operational cost. More importantly, the improvement is proportional to the availability of communication. This works indicates the potential of the "Any-Communication" approach to distributed information-based planning under limited communication.

Qianyi Zhang, Korea Advanced Institute of Science and Technology, South Korea, *Feature-based Global Localization for Underwater Terrain Aided Navigation using Bag of Words*

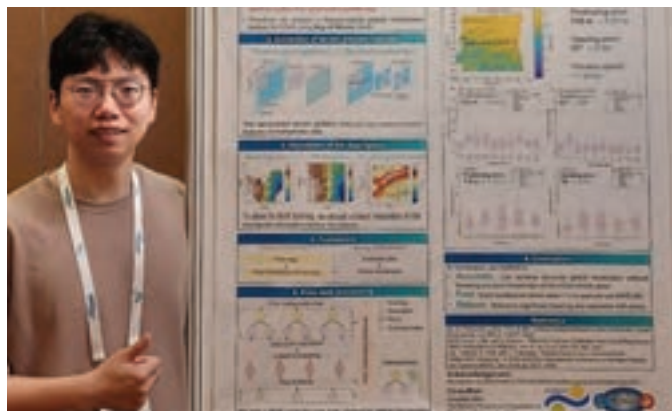

Abstract—This paper presents a novel feature-based global localization method for underwater terrain aided navigation (UTAN) using Bag of Words (BoW). Before the mission, the prior bathymetric map is segmented into submaps, and the handcrafted terrain gradient features are extracted from the submaps. Subsequently, a BoW is trained using these features, and the submaps are indexed accordingly. During the UTAN mission, place recognition is achieved by matching the index of the newly collected submap with the indexes of the submaps in the database, and the vehicle pose is determined using TEASER++ registration method. Experimental results using a sea trial dataset demonstrate that the proposed method can achieve a fast and robust global localization without requiring the prior initial vehicle pose information, offering robustness against substantial initial positioning and heading errors.

Thomas Chové, Thales/IMT Atlantique, France, *Channel Model for Massive MIMO Underwater Acoustic Communications*

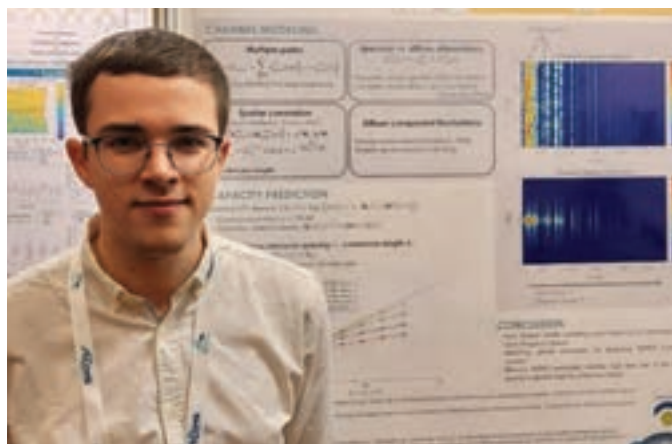

Abstract—Oceans are an environment attracting growing interest, with major economic stakes. There exists a need to design systems able to explore the underwater environment, one of the challenges being the ability to communicate undersea. The underwater acoustic channel is considered as being

one of the most difficult environments for designing communication systems, due to multiple limitations (frequency band, latency, Doppler effect...).

A method that could allow an increase of the data rate is the use of massive MIMO (multiple inputs, multiple outputs) systems, where many transducers are used to emit as well as to receive the signal. The objective of this paper is to present a model for a massive MIMO underwater acoustic communication channel in order to carry out a preliminary analysis of the impact of array correlation on the theoretical achievable rate by using Shannon capacity.

Xu Zhang, Shanghai Jiao Tong University, China, *Design, Simulation, and Experiments of an Underwater Dredging Robot*

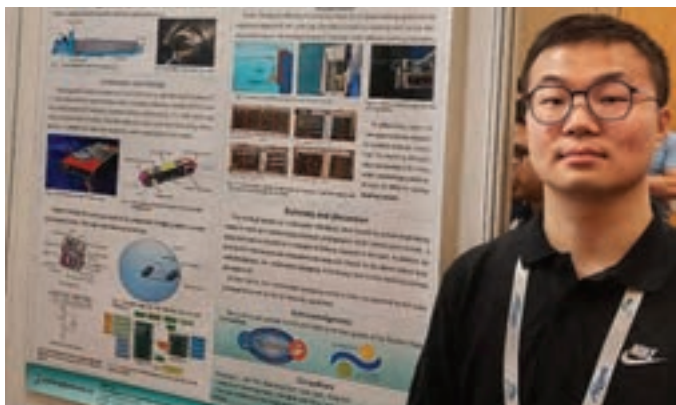

Abstract—The paper studies underwater dredging robots for wall cleaning in long-distance water conveyance tunnels. *Limnoperna fortunei* and other organisms will adhere to water conveyance tunnel walls after a prolonged use, affecting the water's quality. An underwater dredging robot was designed inside the tunnel walls to remove these organisms. The paper proposes a novel mechanical structure for underwater dredging. A detailed description of the machinery and control system of the working section is provided. Tests in actual pool experiments and simulations of nozzles demonstrated that the underwater dredging robot could effectively clean the adsorbed *Limnoperna fortunei*.

Yipeng Meng, Hangzhou Dianzi University, China, *Underwater Target Detection Based on Magnetic Gradient Tensor*



Abstract—The Magnetic Anomaly Detection technique can be applied to locate and identify small-scale magnetic targets underwater. Compared to total magnetic field intensity and magnetic vectors, the magnetic gradient tensor has stronger anti-interference capabilities and provides higher-dimensional information. Utilizing pseudo-color imaging of the magnetic gradient tensor components combined with deep learning can reduce manual intervention and improve identification efficiency and accuracy. However, issues such as sparse measured data and poor magnetic imaging effects lead to poor identification accuracy. To address this, this paper adopts the Kriging interpolation method to increase magnetic gradient tensor data density and proposes an enhanced magnetic anomaly imaging method based on the boundary features of the target magnetic source. Additionally, Coordinate Attention is added to the neural network structure for improvements in identification accuracy. The analysis of finite element simulation data for common underwater magnetic targets demonstrates that the Kriging interpolation method results in smaller errors and higher accuracy compared to traditional linear interpolation methods. The enhanced magnetic anomaly imaging method ensures significantly clearer boundaries while maintaining the intensity of the target magnetic field. Furthermore, the addition of a coordinate attention to the detection model resulted in a 2% improvement in the mapping accuracy. In summary, this work provides a novel solution for the detection of small-scale underwater magnetic targets with different positions, intensities, and shapes.

Jingyu Qian, Zhejiang University, China, *Cross-medium communication combining infrared optical and acoustic waves*

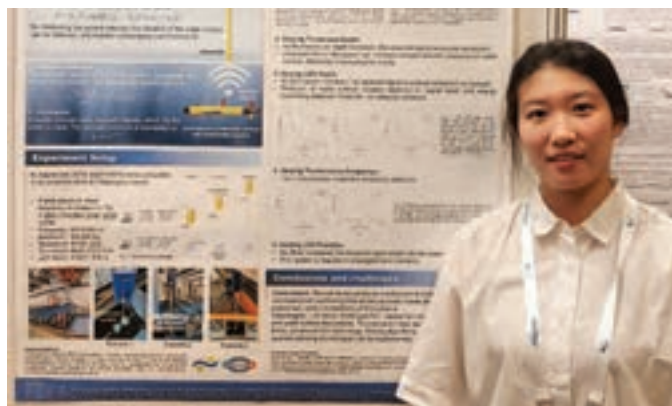

Abstract—In recent years, direct communication across the water-air interface without relay has become possible by combining acoustic and millimetre waves. Present cross-medium communication schemes combining acoustic and electromagnetic waves are carried out in three steps. First, the underwater transducer sends acoustic waves, and the waves hit the water surface and induce vibrations. Then, a millimeter-wave radar in the air sends electromagnetic waves to detect the water surface vibrations. Last, after processing the received signals from the radar, cross-medium communication is achieved. However, this scheme suffers from short communication distances (approximately 1 m over water) and low resolution (millimetre

level). Laser Doppler Vibrometry (LDV) is superior with high resolution and long measuring distances. Therefore, for the first time, we creatively adopted infrared LDV instead of millimeter-wave radar. This new approach improves the communication distance and distance resolution and achieves cross-medium communication with 10.8 m above water and 3.5 m underwater. In this article, we reveal the transmission mechanism of cross-medium communication combining infrared and acoustic waves and use experiments to preliminarily verify the feasibility of this scheme. In our experiments, we evaluate the effects of the depth and carrier frequency of the transmitted acoustic wave signals as well as the height of the receiving end on cross-medium communication.

Jeffrey Shao, University of New South Wales Sydney, Australia, *Fractional Fourier Transform Based Channel Estimation in Underwater Acoustic Communications*

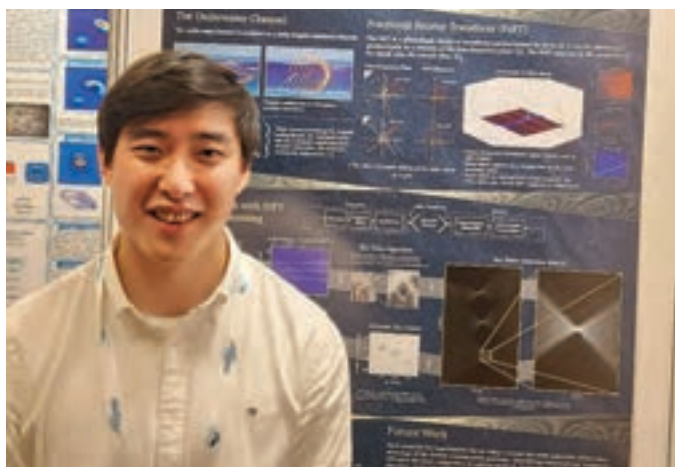

Abstract—Underwater communications have severe channel distortions which can greatly affect its performance. This paper proposes a novel approach for estimating channel parameters (multipath delay and Doppler scaling) for underwater acoustic channels. The method is a Fractional Fourier Transform (FrFT) based approach with linear frequency-modulated (chirp) signals as a pilot. Innovation lies in the receiver design, where a 2D array is formed by performing a scan of FrFTs on the received signal. Key point detection algorithms are exploited to extract distinct X-shaped features in a 2D array, allowing for simultaneous estimation of both channel delay and Doppler parameters for all multipath components. The novel approach avoids the costly iterative process used in existing algorithms, which calculates Doppler scaling for one path per iteration. Simulation results show that the proposed algorithm is capable of estimating channel parameters in a severely time-delayed and Doppler-scaled multipath channel. The algorithm achieved a $\pm 0.1\%$ estimation accuracy with Doppler scaling factors ranging between 0.95 to 1.05. Multipath delay was estimated to within $\pm 2\text{ms}$ for delays ranging from 0 to 0.2 seconds.

Xiao Feng, Northwestern Polytechnical University, China, *Investigation of Three-Dimensional Sound Field Horizontal Refraction in Heterogeneous Topography*

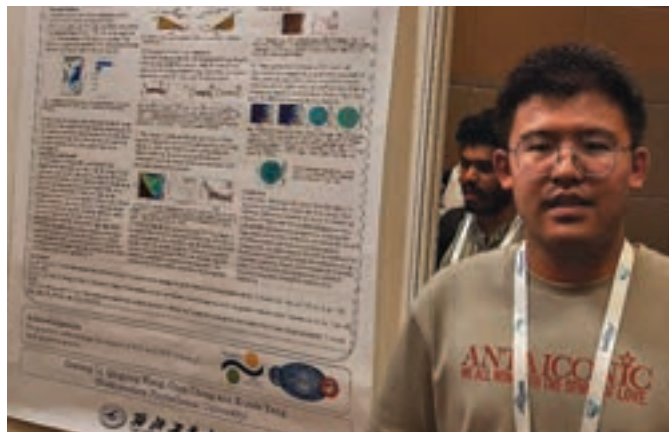

Abstract—The variability in seafloor topography is a primary factor influencing sound propagation. Complex and varied seabed topographies generate differing degrees of sound propagation effects, thereby altering the sound propagation loss compared to a flat seabed. This paper analyzes and statistically processes the slope data of the selected area's terrain. It utilizes acoustic models to simulate and compare the sound propagation loss in convergence zones and near the deep-sea sound channel axis under different slope conditions. The findings indicate that an upslope terrain reduces propagation loss in convergence zones, and the propagation loss is minimized near the deep-sea sound channel axis when the downslope gradient is 7° . The paper also examines and discusses the impact of different bottom sediment parameters on sound propagation loss and the backscattering of acoustic energy in upslope conditions. Finally, the study analyzes the horizontal refraction effect in the three-dimensional sound field under complex terrain conditions from ray trajectories perspective.

Chia-Cheng Hsu, National Taiwan University, Taiwan, *A Guidance Method for A Small Unmanned Surface Vehicle Wireless Charging*

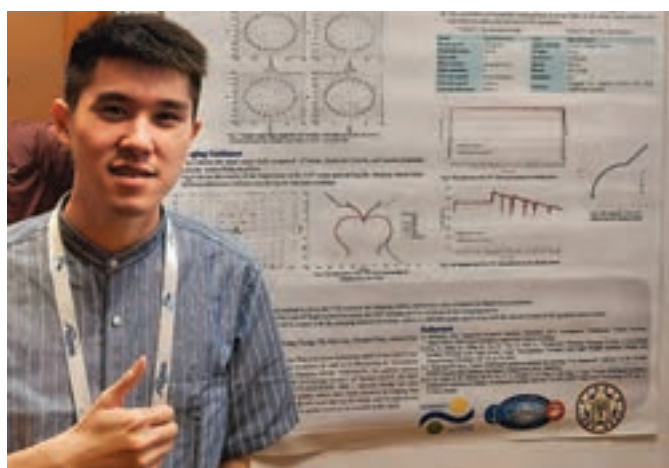

Abstract—A small unmanned surface vehicle (USV) usually carries a limited battery, and the mission duration is also limited. Wireless charging at sea is a way to extend the duration of USV. This work extends the study of developing a vector field-based guidance method for collision avoidance in the ship

simulator. When the USV is in a vector field where near the charging station, the ship follows the vector field for guiding to touch the wireless charging plate. This vector field consists of a straight-line vector field and four circular vector fields in four quadrants to form a heading command to steer the ship. The feasibility of this work is tested by implementing the vector field guidance method into a ship simulator. In this work, the simulation considered wind, wave, and current influences on ship motions and combined the vector field-based guidance method to show the feasibility of the guidance method for USV wireless charging.

John Fischer, Naval Postgraduate School, USA, *UPAD: A Large-Scale Passive Sonar Benchmark Dataset for Vessel Detection and Classification*

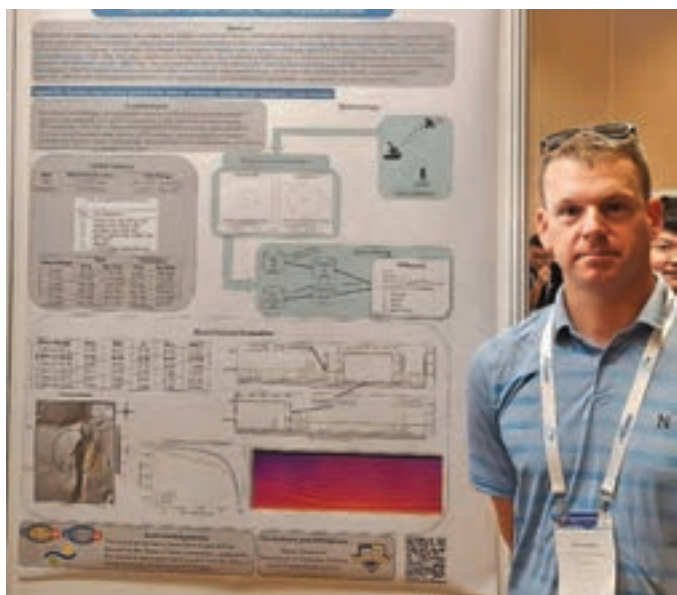

Abstract—In the realm of underwater acoustics, the complex and dynamic environment poses formidable challenges for the detection and classification of vessels through passive sonar systems. Recent strides in deep learning (DL) have sparked optimism in automating or enhancing the data analysis process, traditionally reliant on human expertise. However, the efficacy of DL hinges on substantial training data, a resource currently scarce in the public domain, particularly for annotated real-world passive sonar data. This study endeavors to bridge this gap by presenting a methodology to construct a sizable annotated dataset by leveraging automatic identification system (AIS) data. The outcome of this effort is the Underwater Passive Acoustic Dataset (UPAD), an extensive benchmark dataset meticulously crafted for vessel detection and multi-label classification using passive sonar. UPAD not only addresses the dearth of publicly available benchmark data but also facilitates advancements in the application of DL for navigating the complexities of underwater acoustic environments.

Jinzhi Cai, Hong Kong University of Science and Technology, Hong Kong, *Development of Desktop-Size Marine Swarm Research Platform*

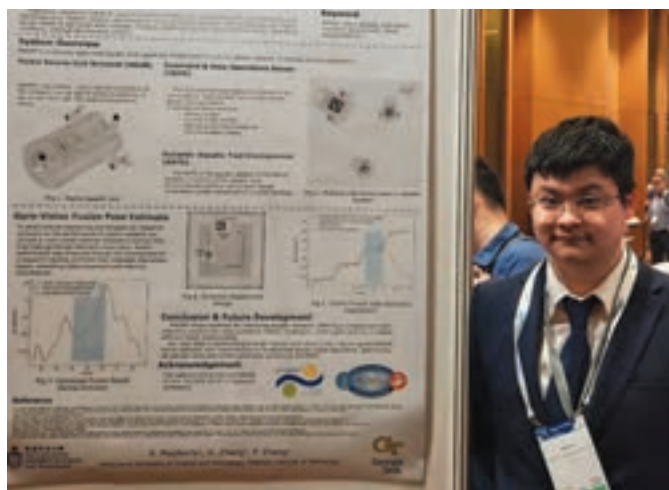

Abstract—Research in aquatic environments often demands extensive facilities, specialized knowledge, and dedicated support staff, which are expensive and usually out of reach for smaller research teams. Establishing accessible research infrastructure, especially with testbeds and freely available software, can reduce entry barriers, shorten the time to implementation, and lessen the likelihood of failure in challenging underwater settings. To address these limitations in aquatic research, we have developed the Marine Automatic Swarm Experiment Platform (MASEP). MASEP is a tabletop-sized, marine swarm robotics testbed for evaluating underwater robotic swarm controllers, novel communication strategies, and more in a simulated aquatic environment. Through MASEP, we have successfully demonstrated the tracking and control of multiple robots, as well validated the robustness and reliability of an external visual localization system when fused with onboard sensor data. By enabling multi-robot tracking in a miniature, low-cost platform, MASEP opens up new possibilities for the advancement of underwater robot swarm testing and the development of effective control algorithms.

Jeremy Coffelt, University of Bremen/ROSEN Creation Center GmbH, Germany, *Segmentation of Multibeam Echosounder Bathymetry and Backscatter*

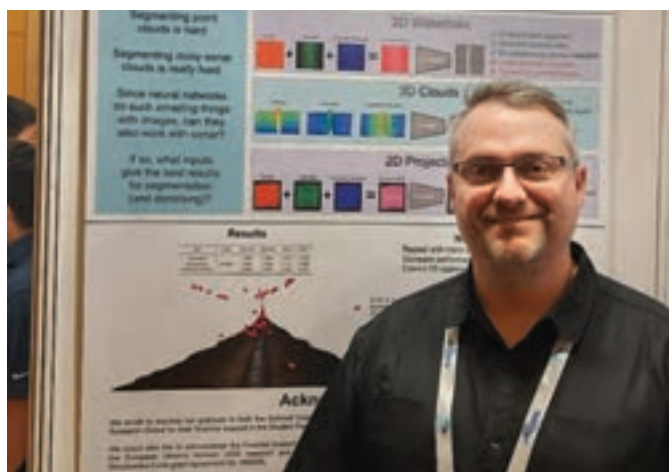

Abstract—Multibeam echosounders (MBES) are the tool of choice for high-precision underwater surveys, especially when water conditions render optical imagery ineffective. We present and evaluate the following approaches for MBES segmentation: (1) real-time processing of single sounding profiles using traditional machine learning techniques, (2) batch processing of “waterfall” pseudo-images using a standard U-Net model, (3) the same model adapted to 2D projections of 3D point clouds, and (4) post-mission, survey-level processing using modern networks specifically designed for sparse point clouds. Strengths and weaknesses of the methods are discussed, including data preprocessing requirements, robustness, and ease of implementation/interpretation. Evaluation is performed on real data collected by an autonomous underwater vehicle (AUV) during a deep-sea industrial pipeline inspection.

Fan Zhao, The University of Tokyo, Japan, *Basic study of deep learning based efficient hermit crabs detection from drone-captured images*

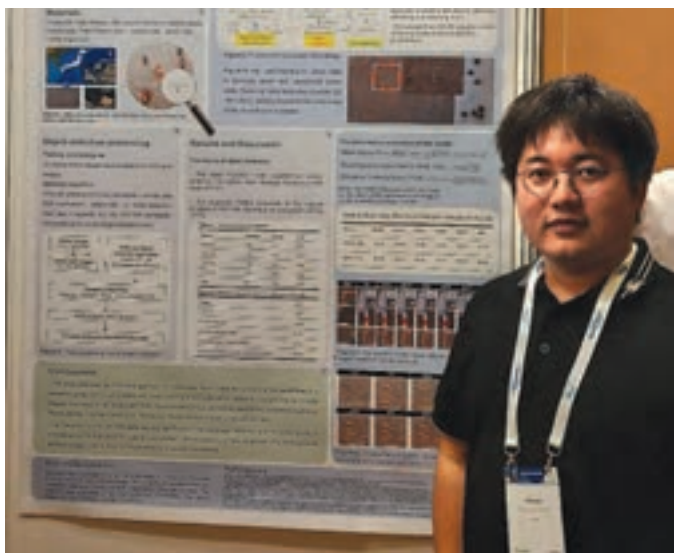

Abstract—The challenges arising from water clarity, depth, and other factors intensify the difficulties in surveying underwater hermit crabs, exacerbated by a notable shortage of practical field surveys. This study introduces a novel approach utilizing consumer-grade Unmanned Aerial Vehicles (UAVs) and deep learning to investigate underwater hermit crabs. We applied diverse super-resolution algorithms, employing distinct design strategies for image enhancement. Furthermore, we

utilized the proposed object detection model developed from YOLOv8, achieving a mean average precision (mAP) of 0.722, surpassing other state-of-the-art object detection algorithms. Applying UAVs and super-resolution technology has significantly progressed underwater hermit crab detection, providing practical solutions for aquatic ecological monitoring, and enabling precise benthos detection.

Xin Qiao, Memorial University of Newfoundland, Canada, *Global Significant Wave Height Retrieval From Spaceborne GNSS-R Using Transformers*

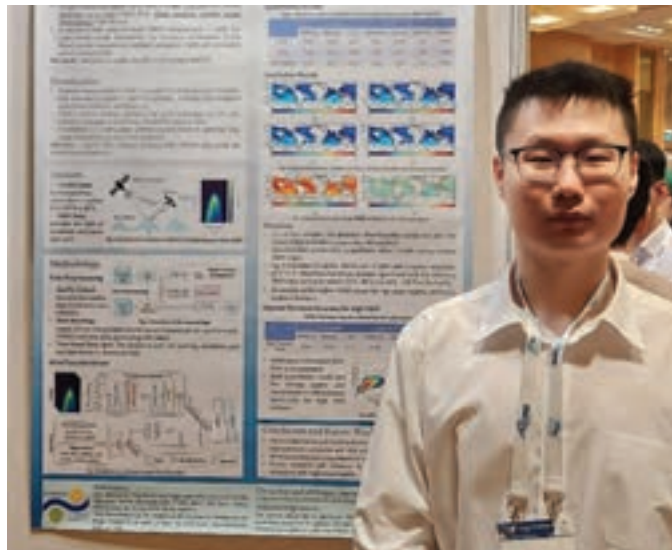

Abstract—Global significant wave height (SWH) is a crucial element in ocean observation and spaceborne global navigation satellite system reflectometry (GNSS-R) stands as a novel remote sensing technique to achieve large-scale measurement. Delay Doppler Map (DDM) is a basic observable of GNSS-R and existing studies have demonstrated the effectiveness of convolutional neural networks (CNNs) in SWH retrieval from DDMs. However, CNNs are constrained by their limited receptive field, lacking the capability to establish long-range dependencies for the entire DDMs. To address this limitation, this paper proposes a novel model called WaveFormer which utilizes transformer architecture to extract features from DDMs. To evaluate the performance of the developed method, experiments are conducted on Cyclone GNSS (CYGNSS) data and results illustrate that WaveFormer achieves a lower root mean square deviation (RMSD) of 0.452 m than the CNN-based method.

OCEANS 2024 Singapore—A First Time for Everything

Jonathan Lephuc, OCEANS 2024 Singapore SPC First Prize Winner

To say my participation in OCEANS 2024 Singapore was a step outside of my comfort zone would be a slight understatement to say the least. OCEANS presented to me a wide range of “firsts”; This was to be my first conference, first poster competition, and first time venturing outside of the United States by myself. To add to the matter, coming from an aerospace background, I had very little idea of what to expect from joining a community of maritime academics and professionals. So naturally, the days leading up to the opening of OCEANS 2024 Singapore were nerve-wracking! However, despite my initial apprehensions, during all of the mixers, receptions, and poster sessions throughout OCEANS 2024 Singapore, I was met with a community that provided me a warm welcome to the world of ocean engineering and marine sciences.

Before I begin discussing my experiences during OCEANS 2024 Singapore at length, I would like to emphasize that none of this would have been possible without the Office of Naval Research Global and the Schmidt Ocean Institute sponsoring the Student Poster Competition (SPC) and covering conference registration, travel, and lodging costs for all 16 student competitors. Because of this, I was incredibly fortunate to have had the opportunity to fly across the world all the way from Houston, Texas, to take part in OCEANS 2024 Singapore and immerse myself in the distinct culture and environment of Singapore for the better part of a week.

On this note, one of my favorite aspects of my time at OCEANS 2024 Singapore was the combination of day-to-day activities with uniquely Singaporean experiences. Everything ranging from the daily train rides to and from the hotel and the Sands Expo Center along the Downtown Line with my SPC roommate to grabbing a quick mid-conference lunch with a group of newly found friends at the Lau Pa Sat hawker center were familiar activities in an exciting, unfamiliar place. Along with trips to the top of the Infinity Pool to take in the nighttime views of the city and evening walks around Marina Bay to the sight of the beautiful light-and-water show, I quickly realized that I simply did not have enough time to see all that I wanted to see! Regardless, the brief sample of time that I had outside of the conference was a rich vertical slice of Singapore’s culture, icons, and attractions that left me with a deep appreciation for my experiences there, as well as a desire to return in the future.

Nevertheless, as much as I had wanted to sightsee and explore Singapore for the entire duration of my stay, I was most excited to share the hard work and achievements of my team and our research with the OCEANS community. The last year

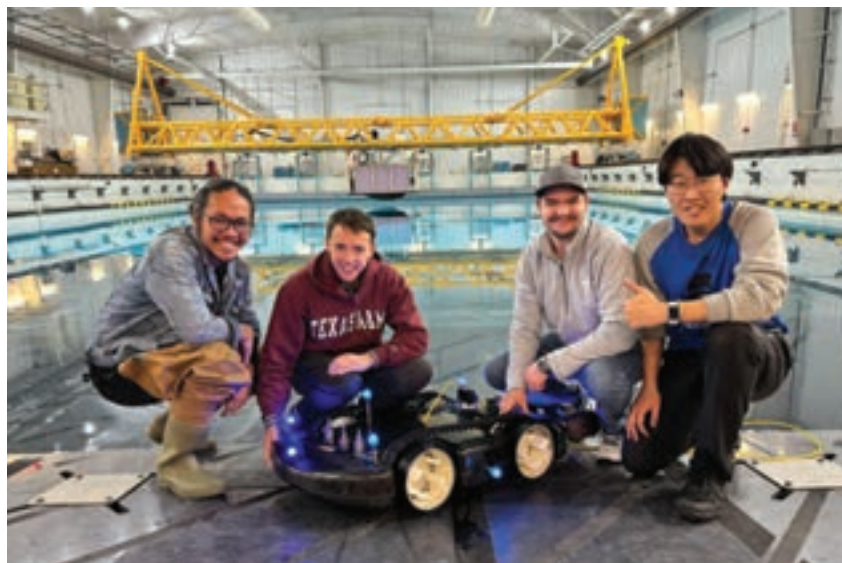

The Cyclo-UUV Team (left-to-right: Jonathan Lephuc, Dr. David Coleman, Cayden Brown, Chenliang Zhang).

of my life was spent developing and testing the world’s first and only amphibious cycloidal propeller unmanned underwater vehicle (Cyclo-UUV) and I had the privilege of introducing my work to this community for the very first time. I had spent the weeks leading up to OCEANS 2024 Singapore fine-tuning my poster’s aesthetics, memorizing a 5-minute brief to give audiences, and poring over any potential questions people might ask me. During each poster presentation, I was met by a wide variety of audiences ranging from UUV experts, underwater robotics engineers, and even a handful of fellow aerospace engineers. What I found was that no matter who I spoke with, I was always left with something new: a piece of technology that may improve future designs, a bit of constructive criticism on my approach, or an anecdote pertaining to a shared challenge.

Overall, it was this exchange of knowledge and expertise from people outside of my own field of research that was one of the most rewarding aspects of my OCEANS 2024 Singapore experience. It was a vital reminder that nobody’s research exists in a bubble and that the capacity to share knowledge and improve upon each other’s work can be found across all disciplines and communities. By the end of the conference, I was fortunate enough to have been selected as the first-place winner of the OCEANS 2024 Singapore SPC, due in no small part to the shared work of the rest of the Cyclo-UUV team. For my first-ever conference, OCEANS 2024 Singapore SPC provided me with a unique and unforgettable experience as well as a warm introduction to the ocean engineering and marine sciences community. And for my *second*-ever conference, I hope to see you all in OCEANS 2024 Halifax!

Maiden Voyage for International Conference: OCEANS 2024 Singapore's Student Poster Competition

Sehwa Chun, OCEANS2024 Singapore SPC Second Prize Winner

In April of this year, I had the privilege of attending the prestigious OCEANS 2024 conference held at Marina Bay Sands Hotel in Singapore. Coming from Korea and studying in Japan, countries where English is not the primary language, I was initially concerned about my ability to communicate effectively at this international gathering. However, the experience proved to be incredibly enriching and surpassed all my expectations.

One of the most delightful aspects of the conference was how quickly and deeply connections were formed during social events such as the welcome reception, poster presentations, and the gala dinner. Despite our diverse backgrounds, and being first-time acquaintances, we quickly found common ground and forged friendships that I believe will last a lifetime. The interaction underscored the essence of academic conferences: a melting pot of cultures and ideas, facilitated by a shared passion for ocean engineering.

As the conference progressed, I began to understand why many researchers are so looking forward to participating in these gatherings. Beyond the exchange of knowledge, they provide a unique space where time seems dedicated solely to discovery and discussion. The environment was buzzing with excitement over new findings, the exchange of innovative ideas, and, not to forget, the enjoyment of awesome cuisine.

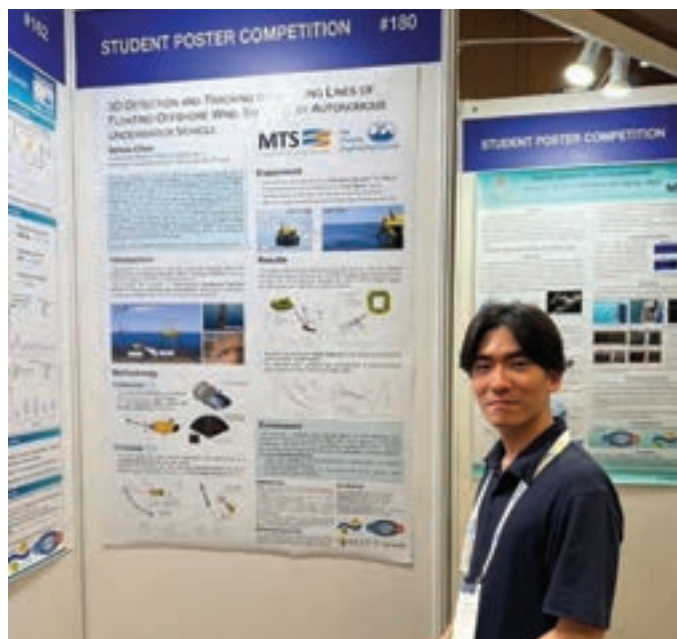

Figure 1. The Student Poster Competition.



Figure 2. The awards ceremony of SPC with the judges.

The conference featured a student poster competition with sixteen remarkable students participating. I presented my research on innovative methods for AUV inspecting mooring chains of floating offshore wind turbines. The lively discussions with the students, the judges and participants not only deepened my understanding but also highlighted the collaborative spirit of the ocean engineering community.

Receiving second place in the poster competition was a significant milestone for me. It not only validated my research efforts but also empowered me to take a more active role in supporting and mentoring new researchers and students. This recognition has inspired me to ensure that newcomers to future conferences feel as welcomed and valued as I did at OCEANS 2024.

Reflecting on the entire experience, being at the Marina Bay Sands Hotel was particularly special. It was a place I had always wished to visit, and to experience it while contributing to a global conference made it even more memorable. The hotel's stunning architecture provided a spectacular background to our discussions and made this special impression unforgettable.

In conclusion, OCEANS 2024 was far more than a mere assembly of experts; it was a vibrant confluence of knowledge, friendship, and inspiration. I left Singapore enriched with new insights, cherished connections, and an invigorated passion for ocean engineering.



Figure 3. The experiment scene of the research presented.

Design and Testing of an Amphibious Cycloidal Propeller Unmanned Underwater Vehicle

Jonathan Lephuc^{1,2} Chenliang Zhang^{1,2} Cayden Brown^{1,2} David Coleman¹ Moble Benedict¹

Abstract—This paper covers the design, development, and testing of a 43 kg (95 lb) amphibious cycloidal propeller unmanned underwater vehicle (Cyclo-UUV) that utilizes a combination of cycloidal propellers (or cyclo-propellers), screw propellers, and tank treads for operations on land and underwater. The use of cyclo-propellers allows for 360° thrust vectoring for more robust dynamic controllability compared to UUVs with conventional screw propellers. Four cyclo-propellers are used to control the Cyclo-UUV while underwater and can be retracted into a set of four wheels to allow for transitioning between underwater and land locomotion. Control of the vehicle underwater is achieved by modulating the cyclo-propeller rotational speed and blade pitch phase angle, allowing for control over the magnitude and direction of the thrust vector of each cyclo-propeller to enable surge, heave, roll, pitch, and yaw motions. These changes to pitch phase angle are controlled by rotary servos which receive commands via an on-board autopilot with an inertial measurement unit (IMU) that measures the vehicle's attitude and stabilizes the vehicle using a proportional-integral-derivative (PID) controller. Systematic testing of the Cyclo-UUV was conducted to verify its mechanical operation, trim the cyclo-propellers for forward motion, tune the PID controller gain values for good response and disturbance rejection, and evaluate the vehicle's performance in both calm water and in the presence of breaking waves similar to those found in the surf zone. The Cyclo-UUV has demonstrated a high degree of maneuverability and controllability in forward motion underwater, as well as the unique capability of performing transitions between land and underwater through breaking waves.

Index Terms—Unmanned underwater vehicles, cycloidal propellers, amphibious unmanned vehicles, surf zone

I. INTRODUCTION

Due to the great importance of Earth's bodies of water for scientific, military, and commercial activities, there is a large demand for multi-modal systems capable of performing complex underwater missions. In this regard, unmanned underwater vehicles (UUVs) are a popular platform for many of these applications due to their lower operational costs and increased safety in comparison to manned systems. UUVs can already be found performing a variety of tasks ranging from military surveillance, mine countermeasures (MCM), environmental monitoring, video collection, and so forth [4], demonstrating the flexibility of UUV capabilities. However,

This work relates to award N000142312410 issued by the Office of Naval Research.

¹J. Lephuc, C. Zhang, C. Brown, D. Coleman, and M. Benedict are with the Department of Aerospace Engineering, Texas A&M University, College Station, TX 77840 USA, {zcl1114@jonathanlep717,ccmb10515,dcaero14,moblebenedict}@tamu.edu

²These authors contributed equally

while research on UUVs in open-water environments is well-developed and understood [13] [14], research on UUVs operating in environments with a high amount of disturbances and obstacles is currently under-represented [5]. This problem is very evident in applications found in the littoral zone (LZ), where the presence of breaking waves in the surf zone (SZ) greatly hinders controllability, and the proximity to land necessitates amphibious capabilities in order to operate within the water-land interface. Having a system that can fuse the roles of both a UUV and an amphibious unmanned ground vehicle (UGV) has the potential to expand the current range of applications for unmanned vehicles in the LZ. This will simultaneously decrease operational complexity by eliminating the need for multiple single-domain underwater and ground vehicles in favor of a single multi-domain vehicle [6].

For instance, while the use of unmanned robotic systems for naval MCM in the LZ has recently entered its nascency using systems like the Explosive Ordnance Disposal Remotely Operated Vehicle [7], current MCM procedures in the SZ and very shallow water (VSW) still require highly specialized teams of human divers and marine mammals to locate and dispose of mines at great risk to their lives [8]. The introduction of an unmanned underwater and ground vehicle that can potentially carry payloads for detection and disposal of mines in VSW, the SZ, and the land itself would dramatically reduce the risk to human life as well as the operational cost and complexity associated with MCM protocol.

Given this need for multi-domain unmanned robotic systems capable of operating in VSW, the SZ, and on land, there are very few of these vehicles within the current state-of-the-art. The POSTECH Multi-Functional Amphibious Vehicle was a proposed 3-in-1 amphibious vehicle that utilized lateral thrusters for operating as a hovering type autonomous underwater vehicle (AUV) and tracks for operating on land as an autonomous ground vehicle (AGV) [9]. However, this vehicle has not been developed beyond initial feasibility studies. Other multi-domain robots like the Hazardous and Extreme environment Robot for Biomimetic multi-Locomotion based Underwater Expedition (HERO-BLUE) [10] and the Amphibious Robotic Turtle (ART) [11] have demonstrated the ability to both swim underwater and crawl on land utilizing biomimetic limbs, but at a scale that is currently too small to facilitate carrying useful payloads. Furthermore, neither of these multi-domain unmanned robotic systems have been tested in the presence of breaking waves similar to those found in the SZ.

With this in mind, the purpose of the current amphibious

cyclo-propeller UUV (Cyclo-UUV), shown in Fig. 1, is to fill this gap in multi-domain vehicle technology. By utilizing cyclo-propellers for propulsion and control, the vehicle has excellent controllability and maneuverability underwater, even in the presence of large disturbances due to waves and currents. These cyclo-propellers are then used in conjunction with wheels and tracks for operating on land as a UGV. A novel aspect of the vehicle design is that the cyclo-propellers can be retracted into the wheels when the vehicle is operating on land, and deployed when underwater. Moreover, the cyclo-propellers and wheels use the same electric powertrain minimizing redundancy and weight. The result is an amphibious vehicle that is uniquely suited for operating in VSW, the SZ and on land.



Fig. 1: Cyclo-propeller Unmanned Underwater Vehicle (Cyclo-UUV).

Cyclo-propellers have been used successfully in marine applications for nearly a century. Cyclo-propellers were introduced in 1927 as the Voith Schneider Propeller (VSP) by the Voith Group based on the design of Ernst Leo Schneider [12]. VSPs are typically mounted on the underside of a surface vessel and consist of a set of parallel propeller blades rotating about a vertical axis, as shown in Fig. 2. The individual propeller blades pitch cyclically about their vertical axes along with a continuous rotation of all the blades about the VSP vertical axis. The rotational speed of the propeller and the blade pitch amplitude determine the magnitude of thrust and the phase angle of the blades' pitch oscillation determines the direction of thrust. This gives the VSP the ability to generate thrust in any direction, providing for propulsion and steering in a single unit without the need for control fins [12]. VSPs are used for surface vessels requiring a large degree of maneuverability and dynamic positioning capabilities such as tugboats, minesweepers, and floating cranes. However, VSPs have yet to be used on any UUVs or unmanned surface vessels (USVs), as these vehicles continue to use conventional screw propellers.

A simulation study conducted by Desai et al. [1] demonstrated the potential of the cyclo-propeller's 360° thrust vectoring capability to enable controlled and agile maneuvering for a UUV. The maneuvering model developed for this study simulated and compared the performance of a cyclo-propeller UUV against that of a screw-propeller UUV with external control fins. It was found that the cyclo-propeller UUV outper-



Fig. 2: Voith Schneider Propellers mounted on a tugboat.

formed the screw-propeller UUV when executing low-speed 180° turns, as control fins were significantly less effective at steering at low forward speeds. Additionally, the thrust vectoring capability of the cyclo-propeller UUV highlighted the cyclo-propeller's potential to perform maneuvers that screw propellers and control fins could not, such as executing a decoupled vertical heave motion without requiring a change in pitch. The simulation results also demonstrated the cyclo-propeller's potential for superior agility and controllability in the presence of large disturbances. This makes the cyclo-propeller concept well-suited for UUV operations in the SZ.

The following sections describe an overview of the design of the Cyclo-UUV and the control methodology using the cyclo-propeller system. In addition, the experiments conducted to verify the functionality of the Cyclo-UUV, tune the onboard feedback control loop, and assess the vehicle's potential to operate in the presence of large breaking waves are discussed. Through these experiments, the Cyclo-UUV has demonstrated the ability to successfully transition between land and underwater through heavy breaking waves. Key results of these experiments are presented as well.

II. DESIGN METHODOLOGY

The Cyclo-UUV is an amphibious vehicle made up of four cyclo-propellers and two screw propellers as shown in Fig. 1. These cyclo-propellers are placed symmetrically on the vehicle such that two are located on the port side, and two on the starboard side. The front two cyclo-propellers from each side are positioned toward the bow and the rear two toward the stern. The two screw propellers serve as rear-mounted thrusters positioned with the propulsive force oriented in the forward direction. As mentioned, the cyclo-propellers can be retracted within the wheels during operation on land. Shown in Fig. 3 is a CAD rendering of the Cyclo-UUV with the rotors retracted. The cyclo-propellers are shown extended for underwater operation in Fig. 4. Figure 5 shows a side view of the CAD rendering of the vehicle with key dimensions included. The vehicle is designed to be symmetric about the horizontal mid-plane so that it can operate even if it lands on the beach upside down.

Even though the cyclo-propellers alone are capable of producing sufficient thrust to propel the vehicle forward and fully control it, the rear thrusters are used to provide additional forward thrust and therefore greater forward speed. Additionally, because the thrusters are positioned on the port and starboard

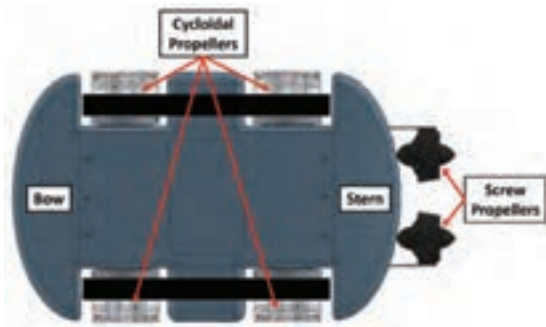

Fig. 3: Top view rendering of Cyclo-UUV with cyclopropellers retracted.

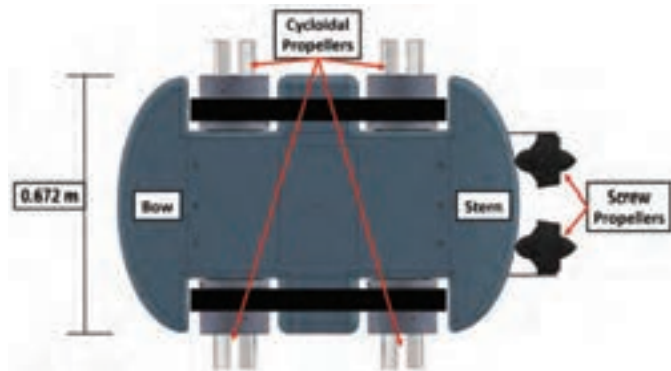

Fig. 4: Top view rendering of Cyclo-UUV with cyclopropellers extended.

sides of the vehicle, they can provide differential thrust levels. This enhances yaw control authority, maneuverability, and yaw rates when coupled to the yaw control of the cyclo-propellers.

The hull of the Cyclo-UUV is constructed of composite materials. It features fiberglass plies at its core with a carbon fiber outer layer. This allows the hull to be molded into complex shapes and have high strength and low weight. The shape of the hull follows a flattened elliptical profile which is intended to decrease the drag on the vehicle and even provide lift, as it operates underwater. The hull is comprised of two separate top and bottom shell pieces which overlap when assembled and that are secured along an outside lip with fasteners.

The Cyclo-UUV utilizes a flooded hull design which does not require a watertight fit between the two halves of the hull. This offers easier accessibility to the internal components during disassembly and for servicing. Due to the flooded design, lightweight polystyrene foam is placed inside the cavities of the hull in order to provide buoyant force. Various



Fig. 5: Side view rendering of Cyclo-UUV.

foam blocks are precisely cut with a CNC (computer numerical control) machine and secured inside the hull to achieve a neutrally buoyant state. All of the electrical components of the vehicle including the servos, motors, thrusters, electronic speed controllers (ESCs), and wiring are all components with at least an IP-68 waterproof rating. The batteries, the flight controller, and the GPS module are located safely inside a waterproof box (electronics enclosure) in the center of the vehicle. Holes in the enclosure for wires have been sealed using waterproof wire pass-throughs and dielectric potting compound.

Additionally, since this vehicle is pilot-operated, a transceiver and receiver are necessary for telemetry. However, since radio frequency signals are heavily attenuated when traveling through water, these components are housed inside a waterproof radio box. This box is placed on a boat-shaped foam buoy that floats on the water's surface and is connected to the vehicle with a 4-meter-long tether shown in Fig. 6. The tether carries the signals from the radio box to the flight controller. The radio box provides telemetry between the transmitter and the vehicle's receiver, as well as between the ground control station and the vehicle's receiver. This buoy is dragged along the surface of the water by the Cyclo-UUV during operation.

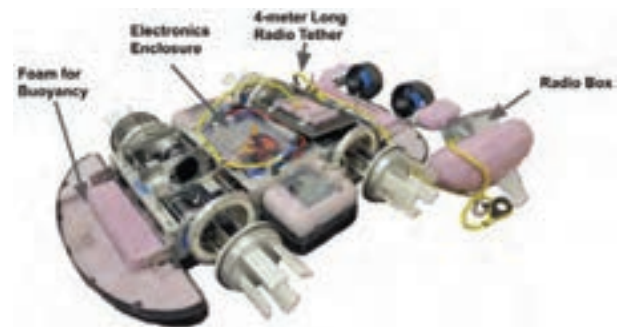

Fig. 6: Cyclo-UUV internal view with top half of hull removed.

A. Cyclo-propeller

Four cyclo-propellers are implemented on the vehicle for control underwater. By altering both the direction of the thrust vector as well as the rotational speed (RPM) of the motors and thus the magnitude of the thrust produced, the pitch, roll, and yaw movements can be executed. The cyclo-propellers and their almost instantaneous thrust vectoring capability give the Cyclo-UUV a unique propulsion and control system.

The principle of operation for cyclo-propeller thrust vectoring is to alter the magnitude and direction of the net force produced by the cyclo-propeller blades. As shown in Fig. 7, the cyclo-propeller generates a net thrust by rotating a series of symmetrically placed blades around a central axis. Simultaneously, the blades oscillate about their blade pitch axes; the pitch angle (θ) of the blades changes as a function of the blade azimuth angle (Ψ) in a once-per-revolution fashion. As a blade rotates about the central point, the maximum

positive θ occurs at the phase offset angle (Φ) of the cyclo-propeller, generating a lift force vector radially outward from the central point along Φ . As the blade rotates past this position, θ begins to decrease until it reaches $\theta = 0^\circ$ at $\Phi + 90^\circ$. This same motion of decreasing θ continues until the blade reaches $\Phi + 180^\circ$. Here, the maximum negative pitch angle occurs. At this location, the blade produces additional lift along Φ , adding to the net thrust of the propeller. As the blade continues to rotate, θ increases until it once again reaches $\theta = 0^\circ$ and eventually returns to its original position (Ψ) and orientation (θ). The azimuthal location of the blade as it rotates about the central point can be followed in Fig. 7. Overall, the lift generated by the rotating blades results in a net thrust produced by the cyclo-propeller. At zero forward speed ($V_\infty = 0$), direction of the net thrust is determined only by the phase offset Φ . However, the forward speed affects the angle of attack and resultant velocity experienced by the blades at different azimuthal locations and therefore, affects both the magnitude and direction of the net thrust for a given blade kinematics and rotational speed [17].

The pitch phase angle of the blades is adjusted by rotating the phasing shaft, which changes the azimuthal orientation of the circular cam located in the center of the phasing mechanism. This, in turn, changes the kinematics of the blades via the pitch linkages that connect the circular cam to the blades. The pitch linkages are located within the central housing of the cyclo-propeller hub. Adjusting the cam phasing changes the Ψ location of the maximum θ for the blades and thus the directionality of the net thrust vector as shown in Fig. 7. Rotation of the circular cam is accomplished by using a rotational servo which changes its angular position based on the pulse width modulation (PWM) signal sent from the onboard flight controller.

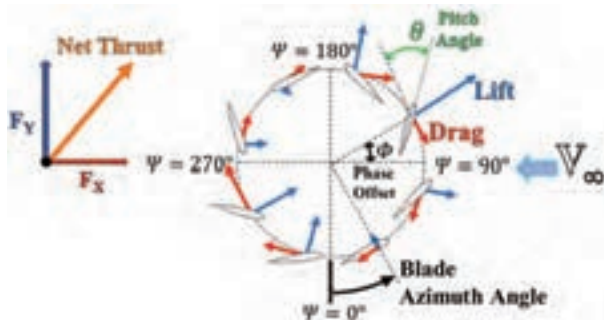

Fig. 7: 2D cyclo-propeller kinematic and force diagram.

The cyclo-propeller design utilizes a four-bladed system with the phasing shaft located at the center of the rotor as seen in Fig. 8. The blades each have a pitching axis which is parallel to the axis of rotation of the entire rotor. The blades have a span of 95.25 mm (3.75 in.), a chord of 40.64 mm (1.6 in.), and are located at a radius of 50.80 mm (2 in.) from the central phasing shaft to their relative pitching axis. The blades feature a NACA 0020 airfoil. These optimized design parameters were based on the findings from [16]. In this study, experiments were conducted for a range of rotational speeds

across different blade pitch amplitudes for cyclo-propeller configurations with varying airfoils, blade spans, chord-by-radius ratios, and number of blades at Reynolds numbers between 100,000 and 300,000. Note that the maximum operating Re of the cyclo-propeller blades on the current vehicle is 193,000.

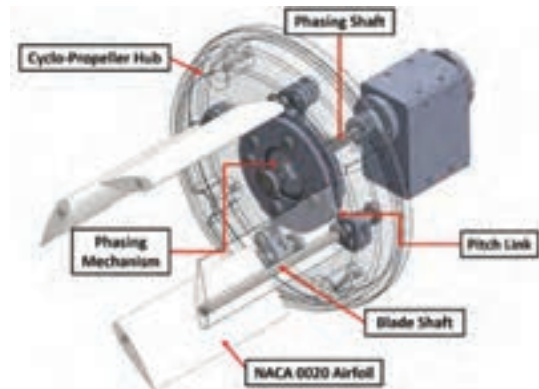

Fig. 8: Cyclo-propeller render.

B. Gearbox

Custom gearboxes were developed for the cyclo-propellers. Four independent 130kv 2000W brushless direct current (BLDC) motors drive the four cyclo-propellers via the gearbox inputs shafts. Each of the motors is connected to the gearbox for each respective cyclo-propeller via a drive shaft with a dual U-joint. This drivetrain, shown in Fig. 9, utilizes a parallel gearbox to redirect the power to the central axis of the cyclo-propeller. The gearbox features bearings on both sides of the input and output shafts thereby eliminating relative motion between the gears. This mitigates any stress on the teeth of the gears due to axis misalignment. A closeup of the gearbox design is shown in Fig. 10. The first purpose served by the gearbox is to provide the required torque at the right RPM at the cyclo-propeller. The second purpose is to accommodate the fact that the cyclo-propeller cannot be directly driven since the pitching axis must pass through the center of the propeller to control the phasing mechanism. As such, the motor must be offset from the center of the rotor. The gearbox features a gear ratio of 5.5:1 between the motor and the propeller. This delivers a maximum of 9 N-m of torque for operation on the ground, while still providing a cyclo-propeller speed of 900 RPM while underwater. The gears themselves were custom-designed for a high contact ratio and fabricated out of 17-4 PH H900 stainless steel to increase the lifetime of the gears.

Additionally, the gear box was designed to be a sealed system such that it could be filled with grease which would lubricate and extend the operating lifetime of the gears. Food-safe grease was used since some vehicle testing would occur in recreational pools. To slow any grease leak, retaining cover plates were placed over the sealed bearings, which support the rotating components of the gearbox. Furthermore, a groove was machined into both halves of the gearbox housing to place an O-ring seal, that compresses when the two halves are fastened together to ensure grease containment. The use



Fig. 9: Cyclo-propeller drivetrain render.

of an enclosed gearbox design filled with grease significantly extended the lifetime of the gears and reduced gear noise over previous open and unlubricated transmission designs.

The gearbox also has tabs located on the backside of the rear half which are used to align and attach the gearbox to the phasing servo support housing. This ensures that the axis of rotation of the phasing servo is concentric with the phasing shaft axis of the propeller. These tabs provide a strong and sturdy attachment for the cyclo-propeller and gearbox to the vehicle. In addition, the tabs provide several mounting points to support the cantilever loads as a result of the propeller mass, cyclic loading, and thrust during operation.

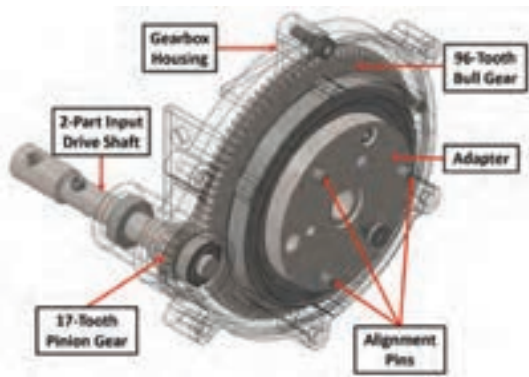

Fig. 10: Cyclo-propeller gearbox render.

C. Retraction System

The retraction system of the Cyclo-UUV, shown in Fig. 11, is a necessity for the amphibious operations of the vehicle. This system consists of two sets of mesh gears and a motor support plate attached to a lead screw. The motor support plate provides an attachment for the motor and the phasing servo, and subsequently the gearbox and cyclo-propeller as well. This effectively makes these components one subsystem which can slide in and out of the wheel hub. This subsystem is aligned using four alignment shafts and driven by the lead screw, which is rotated by a second rotational servo called

the retraction servo. Either mesh gear set 1 or mesh gear set 2 is engaged with its counterpart when the cyclo-propeller subsystem is extended or retracted.

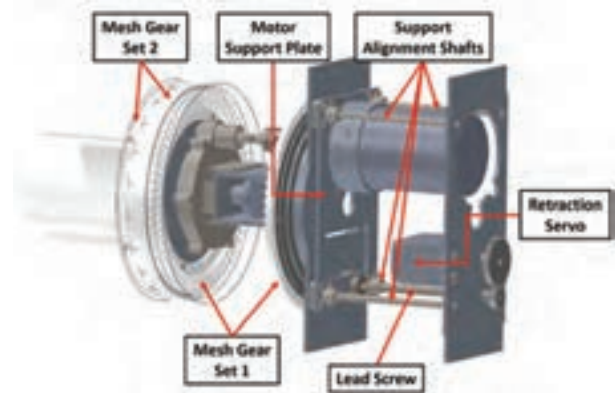

Fig. 11: Full retraction system assembly render (cyclo-propeller fully extended).

When the propellers are retracted, mesh gear set 1 is engaged, which connects the cyclo-propeller to the wheels. This position sets the vehicle up for ground operations and directs the torque from the cyclo-propeller to the wheel hub of the vehicle. As a note, the wheel hub is not shown in Fig. 11 for a clearer view of the mechanism. The torque drives the wheel hub, which in turn rotates the sprocket gear to which the treads are attached. This allows the vehicle to traverse many different terrain types and features.

When the retraction system is extended, mesh gear set 2 is engaged, setting the vehicle up for operation in water. Mesh gear set 2 provides support between the outer hub of the rotating cyclo-propeller and the inner rim of the stationary wheels. A bearing allows the propeller to rotate freely relative to the wheel hub. This mesh gear set helps to remedy the cantilevered condition that occurs by supporting the cyclo-propeller as far outboard as possible. Additionally, in the extended position, the meshing between the gear faces of mesh gear set 2 realigns the cyclo-propeller's central axis to minimize vibration.

III. CONTROL SYSTEM

A. Control Methodology

The control methodology for stabilizing and controlling the Cyclo-UUV's roll, pitch, yaw, and forward speed is achieved through combinations of independent thrust vectoring of the cyclo-propellers, varying the RPMs of the cyclo-propellers, and varying the RPMs of the rear thrusters. The control scheme has been developed based on work presented in [2] and is implemented for all stabilization and control. This methodology is explained in detail here.

Roll: To generate a rolling moment, there must be a difference in the direction of the thrust vectors between the port and starboard cyclo-propellers. Fig. 12 shows the thrust vectors of the two port propellers directed upward while the thrust vectors of the two starboard propellers are directed downward. This

induces a positive right rolling moment about the vehicle's center of gravity (CG). The opposite differential is used for a left rolling moment.

Pitch: A pitch moment is achieved in a similar manner as a rolling moment. However, the difference is applied to the thrust vectors for the bow and stern cyclo-propellers, rather than a difference between the port and starboard. Figure 13 shows the thrust vectors of the two bow propellers directed upward with the thrust vectors of the two stern propellers directed downward. This induces a positive nose-up pitching moment about the vehicle's CG. The opposite differential is employed for a nose-down pitching moment.

Yaw: The generation of a yawing moment involves a difference in the magnitude of the thrust between the two port and two starboard cyclo-propellers while maintaining all four thrust vectors pointing forward. To achieve this change in magnitude, the RPMs of the port cyclo-propellers are increased to generate a larger forward force on the port side of the vehicle, while the RPMs of the starboard cyclo-propellers are decreased to reduce the forward force on the starboard side of the vehicle. This induces a positive yawing moment to the right about the vehicle's CG. The opposite RPM differential is used for a left yaw. Additionally, the rear thrusters are also sometimes used to contribute to the yawing moment by increasing the RPM of the port thruster and decreasing the RPM of the starboard thruster for a right yaw, and vice versa for a left yaw. The schematic for generating yawing moments to the right is shown in Fig. 14.



Fig. 12: Differential thrust vectoring being used to generate a positive rolling moment.

Forward Speed: The forward velocity of the Cyclo-UUV is regulated by adjusting the RPMs and thus the magnitude of all the cyclo-propellers together along with the utilization of rear thrusters for additional forward thrust. Cyclo-propellers are capable of generating thrust at low speeds, while rear thrusters are more hydrodynamically efficient at higher cruising speeds. Consequently, for forward speed control, usually only the cyclo-propellers are employed at lower speeds, while the rear thrusters are added at higher forward cruise speeds.

B. Control Hardware

The control hardware of the Cyclo-UUV includes waterproof electronic speed controllers (ESCs), motors, thrusters,



Fig. 13: Differential thrust vectoring being used to generate a positive pitching moment.

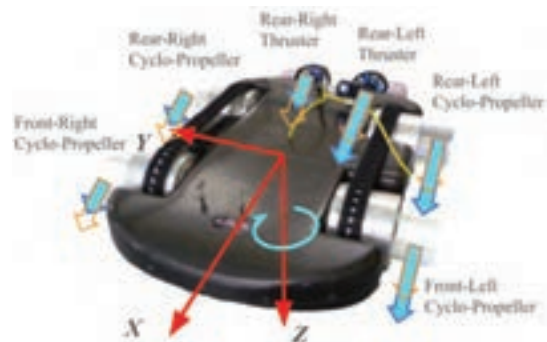

Fig. 14: Differential RPM being used to generate a positive yawing moment.

and servos, as well as the flight control system. Two 6S (48V) 6000mAh lithium polymer (LiPo) batteries power the six ESCs, four motors, and two thrusters, while a 3S (12V) 2200mAh LiPo battery powers the servos and the flight control system. There are eight servos in total. Four function as the phasing servos, which control the direction of each cyclo-propeller thrust vector. The other four function as the retraction servos, which control the retraction or extension of the cyclo-propellers.

The flight control system consists of a flight controller and associated electronics including a transceiver, a GPS module, a receiver, a barometer, and a servo control board. The flight controller houses two STM32 microprocessors for high-end computation tasks and includes an accelerometer and a gyro that provide data for position angles and angular rates. The transceiver is a 500mW, 915Mhz module that provides communication with the ground control station (GCS). The primary function of the GPS module is to provide position and velocity data for ground operations. The receiver acquires commands from the transmitter. The barometer provides depth data for underwater operations. The servo control board is an RS485-to-TTL converter board that enables the flight controller to control the servos.

C. Control Software

The control software is a modified version of the ArduPilot firmware adapted to fit the Cyclo-UUV's control methodology.

This methodology is based on the use of cyclo-propellers and thrusters, which are controlled through inputs from both the pilot and feedback loops. The firmware is responsible for commanding the cyclo-propeller motor RPMs, phasing servo angles, and retraction servo rotation through the use of three different control modes. There are two additional control modes to coordinate the rear thrusters and cyclo-propellers for forward motion.

Water Mode is the mode used to control the vehicle underwater. In this mode, the vehicle's roll, pitch, and yaw are stabilized and controlled using cascaded PID loops. The feedback control loops for roll, pitch, and yaw control are independent of each other. Illustrated in Fig. 15 is the feedback control diagram for executing the Water Mode. As shown in this figure, the pilot roll and pitch angle commands and yaw rate commands are provided as inputs into the cascaded PID loop structure. The gyros and accelerometers inside the flight controller provide the actual (measured) Euler roll and pitch angles, and the actual angular rates, and these are fed back into the PID loops. The PID loops then generate dimensionless (dl) roll, pitch, and yaw control outputs known as factors. These dl factors are then linearly transferred to PWM signal outputs to different actuators.

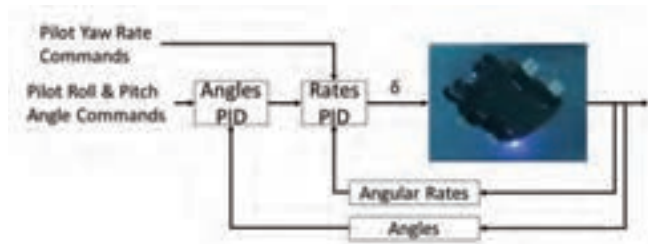

Fig. 15: Water Mode control structure.

Depth Control Mode is the same as Water Mode but with an additional PI controller for regulating Euler pitch angle in order to maintain a constant depth based on pressure measurements from an onboard barometer. The Depth Control Mode structure is shown in Fig. 16. The PI controller directly converts the difference between the desired and the actual depth to a desired Euler pitch angle. As such, the controller goes from position to angle, bypassing the velocity stage of a typical cascaded feedback loop. This step of transferring the position error to a velocity error was not included since actual velocity measurement data is not available while operating underwater. In the current control scheme, the desired Euler pitch angle is determined solely by the depth data from the barometer, enabling complete autonomous depth control. As a result, the pilot has no control over the Euler pitch angle in Depth Control Mode.

In **Ground Mode**, the cyclo-propellers are retracted, the wheels are engaged, and motor RPM is used to drive the vehicle forward and in reverse. The treads are used to steer the vehicle on land using differential RPM between the port and starboard sides of the vehicle. A significant difference

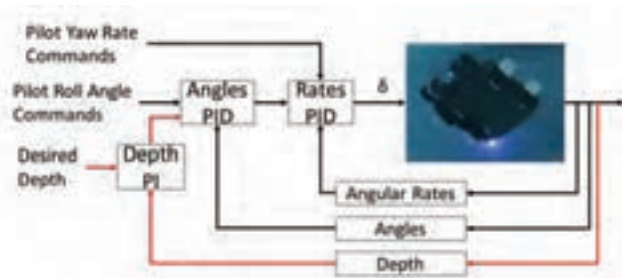

Fig. 16: Depth Control Mode control structure.

between Ground Mode and Water Mode is that the former does not control rolling and pitching as they are not necessary for on-land operations. The Ground Mode control structure is shown in Fig. 17.



Fig. 17: Ground Mode control structure.

Rear Thruster Control features two control sub-modes for coordinating the rear thrusters and cyclo-propellers. These modes include (1) separated control and (2) coordinated control. For separated control, the cyclo-propellers are controlled utilizing the throttle and yaw sticks while the rear thrusters are managed by two rotational knobs on the pilot's transmitter: one for controlling the speed of the rear thrusters and thus the output thrust, and the other for adjusting the differential RPMs between the two for creating yaw moments. On the other hand, the coordinated control permits simultaneous manipulation of both the rear thruster and cyclo-propeller RPM via the throttle and yaw sticks. In this mode, a percentage of the throttle or yaw commands will be sent to the thrusters, resulting in the generation of forward thrust or yaw moments by both the rear thrusters and cyclo-propellers simultaneously.

IV. TESTING

The Cyclo-UUV has undergone successful testing in a variety of environments, including in calm water and in 0.35 m (1.2 ft) waves, as well as on both flat and inclined ground. The underwater testing was first conducted in a 1.22 m (4 ft) deep swimming pool. The purpose of the tests in the swimming pool was to assess the mechanical operation of the vehicle, trim the cyclo-propellers for forward motion, tune the closed-loop PID feedback gains, and evaluate the performance of the depth controller, all in calm water. Testing was then conducted in a 3.05 m (10 ft) deep wave basin, which provided a much larger environment with an inclined artificial beach and a wave generator to simulate wave conditions found in the surf

zone. These tests were conducted to evaluate the vehicle's performance in the presence of breaking waves and deep water waves. Figure 18 shows the wave basin used for testing.



Fig. 18: Wave basin facility at University of Iowa.



Fig. 19: Cyclo-UUV operating in Water Mode.

A. Trim and PID Tuning

The goal of the trim testing was to align the thrust vectors of the cyclo-propellers in the forward direction. This was accomplished by selecting one cyclo-propeller at a time and disabling the rest. The selected propeller was rotated by the motor with the Cyclo-UUV underwater, and the phasing servo trim value was adjusted until the rotor only produced forward horizontal thrust without the pilot providing pitch, roll, or yaw inputs. The process was repeated for the remaining cyclo-propellers, and was essential to prevent dynamic coupling between the axes of the vehicle.

The objective of the PID tuning tests was to fine-tune the cascaded PID loops such that the Cyclo-UUV's motions would be stabilized and the angular positions and rates would track the commands from the pilot. A cascaded PID loop structure was utilized which consisted of an outer loop for controlling the angles and an inner loop for controlling the angular rates. Significant effort was placed on tuning the inner loops, which directly impact the stability and performance of the system. To effectively tune the PID loops, the desired and measured angles and rates were compared until good agreement was achieved. The results of the PID tuning are shown in Fig. 20, 21, and 22, demonstrating that the controller tracked the desired rates well.

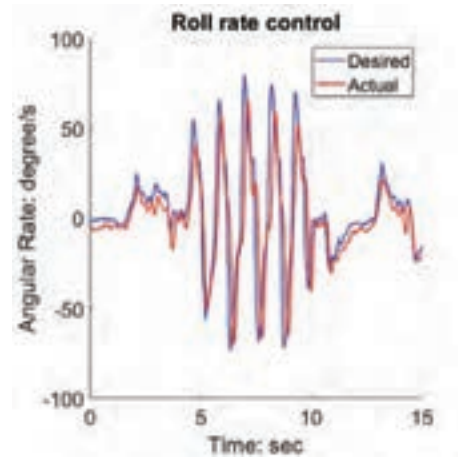

Fig. 20: Feedback tuning results for roll.

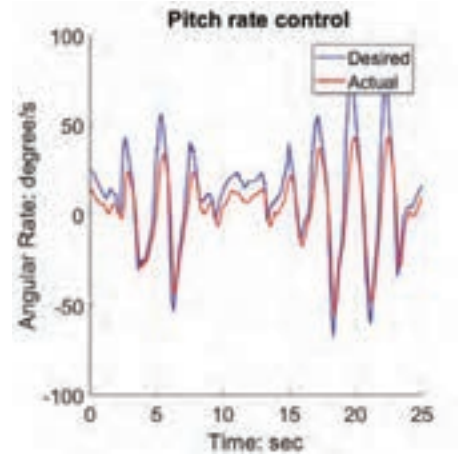

Fig. 21: Feedback tuning results for pitch.

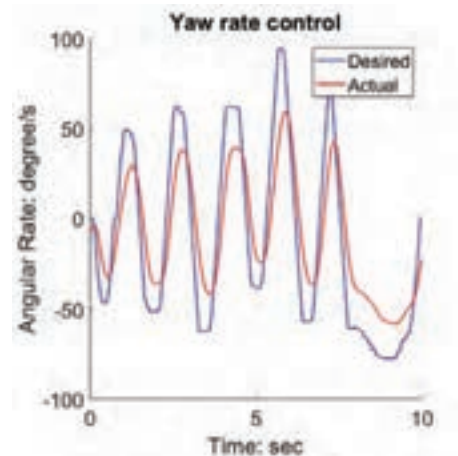

Fig. 22: Feedback tuning results for yaw.

B. Depth Control Testing

After the PID loops were tuned, depth control testing was conducted using the Depth Control Mode. For these tests, the desired depth was the measured depth of the Cyclo-UUV at the moment Depth Control mode was activated, while the measured depth was continuously read from the barometer. While in Depth Control Mode, the pilot carried out various maneuvers without controlling the pitch of the Cyclo-UUV. The depth control tests were conducted in both calm water as well as in the presence of waves. The results of the tests in calm water are shown in Fig. 23, which demonstrates good tracking within about ± 10 cm. The results for the testing in the presence of waves are shown in Fig. 24, which shows greater variation due to the disturbances from the waves, but still within $\approx \pm 17$ cm.

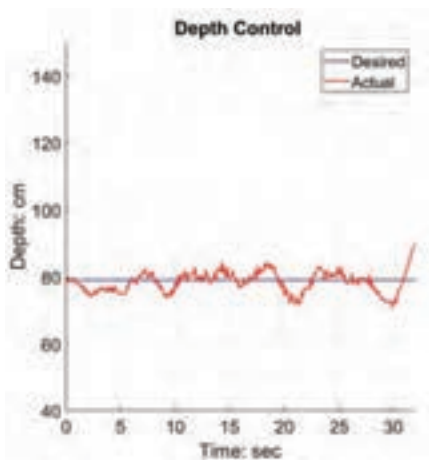

Fig. 23: Depth control in calm water.

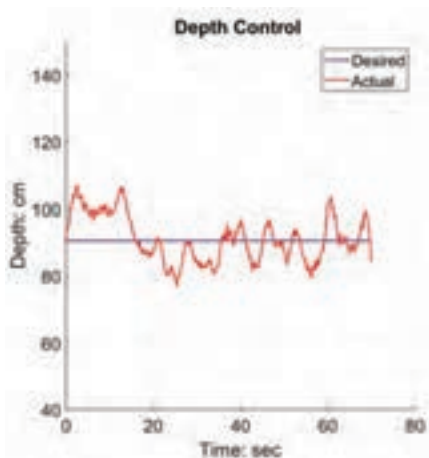

Fig. 24: Depth control in wave condition 8b.

C. Maneuverability Testing

Maneuverability tests were also conducted to evaluate the maneuverability and controllability of the Cyclo-UUV. During these tests, coordinated turns, oscillatory roll, pitch, and yaw, and continuous laps were executed. The angular rates and

accelerations were extracted for roll, pitch, and yaw. These values are shown in Table 1. As can be seen from these results, roll has the largest rates and accelerations due to the fact that the vehicle inertias about that axis are the smallest. During the maneuverability tests, the Cyclo-UUV demonstrated the ability to perform very large-amplitude maneuvers without sacrificing controllability or stability. Additionally, the vehicle qualitatively maneuvers in a very biological manner similar to that of a turtle or ray. This demonstrates the potential of the Cyclo-UUV to rival the maneuverability of current biomimetic underwater vehicles, with the added advantage of the Cyclo-UUV also being an amphibious vehicle capable of operating in the surf zone.

Table 1: Maximum Attitude Rates and Accelerations

Roll Rate	140 deg/sec
Pitch Rate	76.52 deg/sec
Yaw Rate	80.94 deg/sec
Roll Accl.	1243.9 deg/sec ²
Pitch Accl.	1168.9 deg/sec ²
Yaw Accl.	311.86 deg/sec ²

D. Wave Basin Testing

The Wave Basin tests explored the maneuverability and stability of the Cyclo-UUV in various wave states. The vehicle was tested in a variety of wave conditions (WCs), ranging from WC-1 (mild) to WC-8b (severe). WC-1 has a wave height H_0 of 0.13 m, a wavelength λ_0 of 1.96 m, and a frequency ω of 5.61 rad/s. WC-8b has an H_0 equal to 0.35 m, a λ_0 equal to 6.46 m, and an ω equal to 3.08 rad/s. During the tests, the Cyclo-UUV was driven into the waves from the artificial beach using Ground Mode. Initially, the vehicle floats on the surface since water has not yet filled the hull of the vehicle. Then, the rear thrusters are activated to propel the vehicle further from the artificial beach while the cyclo-propellers are extending. Once the cyclo-propellers are extended, Water Mode is activated, and the cyclo-propellers begin spinning. The pilot then commands the vehicle to pitch down to dive beneath the waves. At the end of underwater testing, the Cyclo-UUV is returned to the artificial beach using a reverse procedure. Figure 25 shows the vehicle in the presence of waves while transitioning to underwater operations [15].

During the transition period between land and water, the cyclo-propellers cannot be used for control while extending/retracting. Additionally, the tracks cannot be used to control the vehicle once it leaves the beach, since the vehicle is floating. Therefore, it was found that the rear thrusters are crucial in providing thrust to the vehicle during this transition. The use of the cyclo-propellers, rear thrusters, and tracks during the entire transition between land and water is critical to ensuring that the vehicle remains controllable, especially as the vehicle is being heavily perturbed by the breaking waves.

V. SUMMARY AND CONCLUSIONS

The objective of this work has been to design, develop, and test an amphibious cyclo-propeller UUV that utilizes 360°



Fig. 25: Cyclo-UUV entering water through 0.35 m high breaking waves.

thrust vectoring and variable RPM for 5-DOF control of surge, heave, roll, pitch, and yaw. The goal of this paper is to detail the design and control methodology of the system with four cyclo-propellers. Experimental tests were conducted to verify and test the mechanical systems, tune the onboard PID loops, and assess the vehicle's performance in waves. Some key conclusions from this study include:

- 1) The almost instantaneous 360° thrust vectoring capability of the cyclo-propellers along with the over-actuated nature of the vehicle (8 independent control variables with four cyclo-propellers) allows the vehicle to perform large amplitude maneuvers in roll, pitch, and yaw achieving high angular acceleration (high agility) while remaining stable.
- 2) The cyclo-propellers allow the vehicle to maintain stability and controllability in the presence of waves, even when near the surface of the water demonstrating the high disturbance rejection capability of an underwater vehicle using cyclo-propellers. This can be seen in the vehicle's ability to stabilize its attitude and depth while in forward motion just under the waves.
- 3) It is important to trim each of the four cyclo-propellers independently to ensure that the thrust vector is horizontal and in the direction of forward motion without pitch, roll, or yaw inputs. This prevents dynamic coupling from unintentionally angled thrust vectors.
- 4) The ability to simultaneously use multiple modes of propulsion is crucial during the transition between land and water (and vice-versa), especially through waves. For instance, during the water to land transition, the treads will not have enough traction when the vehicle is partly submerged in water, and hence needs to be complemented by the rear thrusters.

The present work has resulted in an amphibious UUV capable of operating on land and underwater using a combination of cyclo-propellers, screw propellers, and tracks. This is a one-of-a-kind system and is currently the only known cyclo-propeller based underwater vehicle, and maybe even the only amphibious UUV capable of operating in wave conditions similar to those found in the surf zone. The ongoing objective of this project is to conduct field testing of the system in real-world environments and increase the size of the vehicle to better support additional sensors and computing hardware for

autonomous operation as well as other useful payloads.

VI. ACKNOWLEDGMENT

The authors would like to thank previous Advanced Vertical Flight Laboratory students, John White and Darragh Farrell, for their work in the early stage design and development of the Cyclo-UUV. The authors would also like to extend our thanks to Dr. Casey Harwood, Mike Swafford, and the staff and faculty of the Hydraulics Wave Basin Facility at the University of Iowa for their support during the wave basin testing. This work relates to award N000142312410 issued by the Office of Naval Research.

REFERENCES

- [1] M. Desai, M. Benedict, Y. L. Young. "Augmenting Maneuverability of UUVs with Cycloidal Propellers", Preprints. 2022, <https://doi.org/10.20944/preprints202005.0434.v2>
- [2] M. Desai, A. Halder, M. Benedict, Y. L. Young. "A control scheme for 360° thrust vectoring of cycloidal propellers with forward speed", *Ocean Engineering*, Volume 249, 2022, 110833, ISSN 0029-8018, <https://doi.org/10.1016/j.oceaneng.2022.110833>
- [3] M. Benedict, T. Jarugumilli, I. Chopra. "Effect of Rotor Geometry and Blade Kinematics on Cycloidal Rotor Hover Performance", *Journal of Aircraft*, Vol. 50, No. 5, September-October 2013
- [4] A. Sahoo, S. Dwivedy, P. Robi. "Advancements in the field of autonomous underwater vehicle," *Ocean Engineering*, Volume 181, 2019, ISSN 0029-8018, <https://doi.org/10.1016/j.oceaneng.2019.04.011>
- [5] M. Borg, "Autonomous Amphibious Robot Navigation Through the Littoral Zone," PhD Thesis, 2021
- [6] S.-C. Yu et al., "Preliminary Study on Robotic Amphibious Vehicle," Proceedings of the Twenty-first (2011) International Offshore and Polar Engineering Conference, Maui, Hawaii, 2011, pp. 264-268
- [7] J. Schmidt, "Leon and the Corps' Robotic Revolution in the Global Littorals," *Marines*, <https://www.marines.mil/News/News-Display/Article/3580704/leon-and-the-corps-robotic-revolution-in-the-global-littorals/> (accessed Jan. 27, 2024).
- [8] M. R. Blackburn, R. T. Laird, and H.R. Everett, "Unmanned Ground Vehicle (UGV) Lessons Learned," SPAWAR Systems Center, <https://apps.dtic.mil/sti/tr/pdf/ADA495124.pdf>
- [9] S. -C. Yu et al., "The development of multi-functional autonomous amphibious vehicle," 2011 IEEE Symposium on Underwater Technology and Workshop on Scientific Use of Submarine Cables and Related Technologies, Tokyo, Japan, 2011, pp. 1-6
- [10] T. Kim, J. Kim and S. -C. Yu, "Development of Bioinspired Multimodal Underwater Robot "HERO-BLUE" for Walking, Swimming, and Crawling," in *IEEE Transactions on Robotics*
- [11] R. Baines, S.K. Patiballa, J. Booth et al. "Multi-environment robotic transitions through adaptive morphogenesis." *Nature* 610, pp. 283-289
- [12] D. Jurgens, M. Palm, S. Singer, and K. Urban, "Numerical optimization of the Voith-Schneider® Propeller," *Z. angew. Math. Mech.*, pp 689-710
- [13] J. E. Manley, "Unmanned Maritime Vehicles, 20 years of commercial and technical evolution," *OCEANS 2016 MTS/IEEE Monterey*, Monterey, CA, USA, 2016, pp. 1-6
- [14] Y. R. Petillot, G. Antonelli, G. Casalino and F. Ferreira, "Underwater Robots: From Remotely Operated Vehicles to Intervention-Autonomous Underwater Vehicles," in *IEEE Robotics & Automation Magazine*, vol. 26, no. 2, pp. 94-101, June 2019
- [15] J. Lephuc, *Cyclo-UUV Demo Video*. (Jan 30, 2024). Accessed: Jan. 30, 2024. [Online video]. Available: <https://www.youtube.com/watch?v=QVIs1fDQdu4>
- [16] A. Kellen, "PERFORMANCE MEASUREMENTS ON A UAV-SCALE CYCLOIDAL ROTOR IN HOVER", Texas A&M University, Master's Thesis, 2019
- [17] J. Heimerl, A. Halder, M. Benedict, "Experimental and Computational Investigation of a UAV-Scale Cycloidal Rotor in Forward Flight", Conference: Vertical Flight Society's 77th Annual Forum & Technology Display, May 2021

OCEANS

CONFERENCE & EXPOSITION

2 0 2 4

HALIFAX

September 23-26, 2024

Join experts, researchers, and industry
leaders from around the world shaping
the future of tomorrow's ocean



FIND OUT MORE AT
halifax24.oceansconference.org

16-19
JUNE
2025

Le Quartz
Congress
Centre Brest
France

OCEANS
2025
BREST



OCEANS: INFINITY
IS THE LIMIT

OCEANS

CONFERENCE & EXPOSITION

OCEANS:
INFINITY
IS THE
LIMIT



OCEANS

CONFERENCE & EXPOSITION

OCEANS
2025
BREST



OCEANS:
infinity
is the
limit

Graphic Design: severinechaussey.com

City of Brest

Brest in Finistère, Pen Ar Bed, the beginning of the world: steep cliffs, long sandy beaches, sharp reefs and the blue of Armor (“land of the Sea”), the hills and green of Argoat (“land of the Woods”).

Brest in Brittany, a rich heritage of Breton culture: language, music, dance and a “spirit” – open to the world, curious about others and willing to share its wealth and diversity.

Brest’s geographical location, combined with the know-how of local companies, research institutes and a strong oceanographic tradition have all made Brest a focal point of excellence regarding the ocean. This location reinforces, both nationally and internationally, the strong position held by Brest and its region in:

OCEANS 2025 BREST Emphasis

- > Environmental Engineering,
- > Energy from the Oceans,
- > Digital Ocean,
- > Industrial activities related to the ocean

Contact: r.garello@ieee.org
<https://brest25.oceansconference.org>

OCEANS Conference

The **OCEANS Conference** is a major forum for scientists, engineers and end-users throughout the world for presenting the latest research results, ideas, developments and applications in all areas of Oceanic Engineering systems.

OCEANS 2025 Brest program will be built around the theme “**Oceans: Infinity is the Limit**”, with an emphasis on the impact of climate change in the oceans and from the oceans. The technical sessions will provide a review of recent advances in oceanic engineering, science and technology.

OCEANS 2025 Brest will comprise both a SCIENTIFIC CONFERENCE (oral and poster presentations) and a large State of the Art EXHIBITION in the field of **Engineering and Marine Technology**. Both will take place in the Brest downtown cozy conference center “Le Quartz”.

Local Organizing Committee

General Chair

René Garello
IMT Atlantique / IEEE OES

Honorary co-chair

Christophe Lerouge
Director IMT Atlantique

Technical Chair

Christophe Laot
IMT Atlantique

Co-chairs

Jérôme Mars (GIPSA-Lab, Université Grenoble Alpes)
Isabelle Quidu (ENSTA Bretagne)

Treasurer

Pascal Lorenz
IEEE France

Exhibit Chair

Céline Liret
Scientific Director, Oceanopolis, Brest

Student & Student Posters & Posters

Frédéric Maussang (IMT Atlantique)
Pierre-Jean Bouvet (ISEN Brest)

Tutorial Chair

Julien Bonnel
Woods Hole Oceanographic Institution / IEEE
OES

Local Arrangement

Olivia Lahens
Technopôle Brest-Iroise

Conference Center

Clémentine Floch
Brest’Aim Events - Le Quartz Congrès

Who's Who in the IEEE OES

Prof. Nikola Mišković, University of Zagreb, Faculty of Electrical Engineering and Computing, Laboratory for Underwater Systems and Technologies (LABUST)

My name is Nikola Mišković and I am a Full Professor of control and marine robotics at the University of Zagreb, Faculty of Electrical Engineering and Computing (FER). My journey into the fascinating world of marine robotics began in 2005 under the mentorship of Prof. Zoran Vukić who offered me the opportunity to undertake my MSc thesis in marine robotics, igniting a passion that would shape my academic and professional trajectory. At about the same time, Prof. Vukić officially founded the Laboratory for Underwater Systems and Technologies (LABUST)—since then it has significantly contributed to positioning Croatia on the world map of marine robotics research. In 2019 I would become the head of LABUST when Prof. Vukic retired.

I completed my Ph.D. in 2010. During this, I had the privilege of spending valuable time at the Consiglio Nazionale delle Ricerche in Genova, collaborating closely with Massimo Caccia and his team. This collaborative endeavor laid the groundwork for a fruitful friendship and ongoing research collaboration that continues to bear fruit to this day. In 2011, I embarked on my tenure as an Assistant Professor, and I became a Full Professor in 2019.

My leadership journey has been defined by a commitment to excellence and innovation. At the age of 33, I coordinated my first EU project, “CADDY—Cognitive Autonomous Diving Buddy,” a pioneering endeavor that explored human-diver interaction research. Since then, I have led numerous international and national projects, fostering collaboration with esteemed institutions worldwide. Since then, I coordinated a number of international (EU, ONR, Interreg) as well as national projects, and participated in many more. In addition to my research pursuits, I have served as the vice dean for research from 2018 to 2022 at my faculty.

However, my true passion lies in mentoring the next generation of researchers and scholars. Watching my Ph.D. students

achieve remarkable milestones, such as winning the prize for the best-performing team in the Mohamed Bin Zayed International Robotics Challenge (MBZIRC 2023), fills me with immense pride and joy.

One important thing that Prof. Vukić taught me is the importance of international networking within the research community. In line with this lesson, I have been involved with the organization of “Breaking the Surface” workshop that has been contributing to the community for the last 16 years.

As a member of the IEEE OES since 2006, I am deeply committed to contributing to the strategic direction of the society, particularly in the areas of networking and mentoring. I believe that nurturing the next generation



Me surrounded by autonomous marine vehicles developed in LABUST during an interview in 2018.



Blast from the past—me doing experiments at the Lake Jarun in Zagreb in 2011.



Welcome speech during “Breaking the Surface 2022” opening in Biograd na Moru, Croatia.



“Breaking the Surface 2022” group photo, Biograd na Mor, Croatia.

of leaders is paramount to the continued advancement of our field.

Beyond academia, I am a devoted husband and father. In 2015, I married my wife, and together we welcomed

our daughter Mila in 2017, followed by our son Maksim in 2021. Their presence brings immense joy and inspiration to my life, and I am grateful for their unwavering support and love.

Request for OES AdCom Nominations

IEEE Oceanic Engineering Society Election of Members to the Administrative Committee

For a Three-Year Term 1 January 2025–31 December 2027

Jerry Carroll, Chair of IEEE/OES Awards and Nominations Committee

The OES Administrative Committee election closes on 18 July 2024. This time, we have the following 14 candidates from around the world. You can see candidates’ bios and statements on the voting site.

Candidates

Farheen Fauziya
Brian Horsburgh
Weimin Huang
Bharath Kalyan

Lian Lian
Francesco Maurelli
Suleman Mazhar
Laura Meyer

Maurizio Migliaccio
Rosmiwati Mohd Mokhtar
Jacqueline Nichols
Ananya Sen Gupta

Kanika Singh
Harumi Sugimatsu

VOTE NOW at <https://eballot.app/ieee>

You will need your IEEE Account username/password to access the ballot. For quick reference, your username is **your email address**. If you do not remember your password, you may retrieve it on the voter login page.

Important Access Information: Please make sure you are signed out of all other applications in your browser before attempting to log into the voting site. If you are having trouble accessing the site, it could be because you are not signed in to your IEEE Account and recommend that you copy the link and paste into 1) a private browsing window if using Firefox or 2) an incognito window if using Chrome, and log in with your IEEE Account information.

If you have any questions about the IEEE Oceanic Engineering Society voting process, please contact ieee-oevote@ieee.org or +1 732 562 3904.

Welcome New and Reinstated Members

From 12 February through 6 May 2024

Total: 116 (incl 66 student)

Brazil

Andre L. Belem
Silvana Cristina Paz do Couto
Millena Junger
Andrea E Silva Oppenheimer
Daniel Maia Ramos
Joao Victor Dos Santos
Ribeiro
Virna Barbosa Vieira

Canada

Nicholas Mark Gee

Chile

Grace Maria Mena

China

Zhixiong Gong
Yonggang Ji
Hua Li
Juan Li
Lu Ma
Guang Pan
Syed Hayder Ali Shah
Zhigang Shang
Xuwang Song
Ye Yang
Yayu Yang

Colombia

Alfredo Luis Rodrigues
Jimenez
Miguel Ruiz Sanchez

Denmark

Olaya Alvarez Tunon
Fredrik Fogh Soerensen
Malte Von Benzon

Ecuador

Lady Nicole Macas

France

Williams Ukaegbu Orji

Germany

Emanuele Coccolo

India

Nandana C A
Harinand A S
Mohamed Musthafa AK
Lena Alphonsa Jojo
Satvik Aryan
Harikrishna C
Anan Fathima
Jyolsna Joji Isac
Shyam Kesavan Jayasankar
Anupama Jims
Muhammad Nabeel K
Sarang K
Vyshnav K
Suhana Kn
Adithdev Kr
Malini M M
M Mohith
Karthik Nandakumar Nair
Karthick Pandian P V
Fazna P. F
Srinidhi Ponnada
Hari Govind R
Pradeepa R
Soorya Narayanan R
Vijay Krishna RV
Raghavendran S
Nilanjan Saha
Roshan Sathyanathan
Aliya Shahul
Mohammed Shan MR
Shijil Shijo
Puppala Shilpa
Anfal Hisham Thangal P
Gopika V K
Shweta Kishan Yadav

Italy

Mirko Barbuto
Alessandro Faggiani

Japan

Mitsuyasu Deguchi
Gen Li
Ken Takagi
Hirokazu Yamagata

Korea, Republic of

Yeongjun Lee

Mexico

Fernando Gomez
Alejandra Ramirez Meneses

Norway

Guoyuan Li

Panama

Stephanie Arango

Peru

Deyaneira Shalin Deudor
Nain Maximo Ramos
Anghello Eduardo Rodriguez
Risco
Ariana Quetzal Rojas
Kathia Micchelle Segura

Philippines

Jason Garaygay Khaw

Portugal

Antonio Oliveira
Haitong Xu

Spain

Timothy J Murphy

Tunisia

Eya Mezni
BenAissa Mounir
Yassine Soussi

United Kingdom

Timothy C Tozer

Uruguay

Mariana Lecor

USA

Charles Lawrence Bernstein
Sarah Brent
Rain Byars
Thomas William Cassidy
Rusita Desai
William L Dibble
Cassandra M Donatelli
Darnell Gadberry
Hasan Adil Gokturk
Samuel Jacob Gurgone
Coltin Haniotakis
Brian K Haus
Charles K Heatherly III
Kerry C Ireland
Kevin Lyons
Ray Mahr
Donald E Martens
Micajah Ziegler McGarity
Brendan McNelly
Roger M Oba
Nirmal Paudel
Carla Peterson
Zippora Rutty
A T
Gabriel Ricardo Venegas
Sarah Watson
Mohammad Mustahsin Zarif
Yifan Zhou

How to Receive Paper Copies of Each Beacon

Although digital versions of the Beacon newsletter are available on the OES website (<https://ieeooes.org/publications/oes-beacon/>), only OES members can receive printed copies of each Beacon.

Here is how to get your paper copies of the OES Beacon in the future. Introduction is also on the above OES website.

- 1) OES members need to contact the IEEE Contact Center at 1-800-678-4333 or 1-732-981-0060- Monday thru Friday- 8:00 AM- 4:30 PM EST.
- 2) Or... send the IEEE Contact Center an email at contactcenter@ieee.org with your name, IEEE member number and your request to receive your paper copy of the OES Beacon. Please enjoy the BEACON newsletter.



BEACON Newsletter archive website.

OTC Asia 2024 Experiences

Student Members of the OES Malaysia Chapter

At OTC Asia 2024, student members of the OES Malaysia Chapter volunteered to support OES promotions. The followings are the reports on their experiences at the conference.

By Syahmi Hakim

From 27th of February to 1st of March, 2024, Offshore Technology Conference (OTC) Asia was held at Kuala Lumpur Convention Centre (KLCC) for the professionals to exchange their ideas and innovations with others about current offshore energy industry. I was there as a volunteer with Thaqif Iman and Jayraj Singh to attend the booth for IEEE Oceanic Engineering Society (IEEE OES) under supervision of Assoc. Prof. Ir. Dr. Zool Hilmi. Not only were both of us attending the booth, but also

some of the society members of IEEE OES also attended the booth such as Elizabeth Creed, Bill Kirkwood, Pallayil Venugopalan and also Harumi Sugimatsu. Not to forget, we also met with the president of IEEE OES, Christopher Whitt. Along with the event, I learned many things about current offshore technology and met with many great people.

Throughout the event, we met with many people, not only from Malaysia, but also from around the globe. When the students came to our booth and were curious about what is the IEEE OES, we explained to them briefly about IEEE OES and the benefits of joining the society for the students. Some of them took the interest to join the society when we showed them how to register online. Some of them also liked to spread the



Attending the IEEE OES booth in OTC Asia 2024.

news about society through their respective universities and colleges by snapping the picture of the IEEE registration website and the benefit of the member. Some of them were also hoping to join the society after their graduation by registering as a graduate student member if they continue their study in Master or as young professional.



Tha'qif Iman explaining about IEEE OES to the student.

Not only did we meet with many other students, we also met with other professionals in their respective industry. For myself, I met with a person who is in charge inside the Minis-

try of Human Resources Malaysia, explaining the current issues of graduate employability and skill nowadays. Not only that, he also gave me tips on to secure the good job for a better future, such as improving the soft skill and less job hopping after getting the job. I also was fortunate to meet with the R&D department staff of the Ministry of Defence Malaysia, Mr. Sya'fiq, about his wish to do collaboration for their project of ROV in the ministry. He also explained how, inside his department, he needs more young people so they have fresh and creative ideas on how designing the project. Not only from Malaysian, I also met with other overseas professionals, such as from China, Japan and Middle East, explaining to them about IEEE OES and the benefits for them. Some of them took an interest and would like to know more about IEEE OES by exchanging name cards.



Mr. Sya'fiq checking the IEEE OES Newsletter BEACON.

I not only attended the booth, but I also went to other booths as well to learn more about offshore technologies. At first, I has the mindset that this event was just for the oil and gas industry only, but after attending many booths at OTC Asia, I learned that many companies also need many Electrical and Electronic, Mechanical and Computer Science engineers for their projects. All of them implement the Industrial Revolution 4.0 and Internet of Things for their new projects. Not only that, they also implement the use of Artificial Intelligence (AI) and robotics inside their projects. This exposure made me realize that the oil and gas industry needs more skilled graduates from other fields. I also learned the new current projects that many of them were working on, such as robot implementation for checking and inspection on the oil rig, the use of optic fibre inside an oil rig for precise measurement, use of AI for searching new oil rigs and net zero decarbonization for old oil rigs. I also learned that a big company such as PTTEP developed a smart city in Virtual Reality (VR) based on Bangkok, Thailand, to simulate



Me with the IEEE OES Members (From left: Bill Kirkwood, Elizabeth Creed, Harumi Sugimatsu, Syahmi Hakim, Pallayil Venugopalan and Thaqif Iman.)



Promotion at the IEEE OES booth.

the city and also town planning. They also use this project to predict any disaster that can occur at the city with using the AI.

Last but not least, joining OTC Asia was not only worth my time, but gave me new opportunities to learn more about current offshore technology. Not only did I make connections with other professionals, I also learned from them more about their experience and opportunity to work with them in the future. I hope I can attend this event next time to grab a new opportunity to learn more about offshore technology.

By Thaqif Iman

Joining the Offshore Technology Conference (OTC) at the KLCC Convention Centre was a whole new experience for me. It felt like diving into a sea of seasoned professionals and influential figures from oil and gas companies worldwide. But I wasn't alone; my buddy Syahmi from UTM KL and I were there representing the IEEE Oceanic Engineering Society (OES) at our booth.

Meeting incredible individuals like Dr. Zool, Elizabeth Creed, William Kirkwood, Pallayil Venugopalan and Harumi Sugimatsu was a highlight. They were not just amazing to work

with, but also generous in sharing their knowledge. Chatting with them and the visitors to our booth helped me sharpen my communication skills.

The event aimed to shed light on the latest happenings in the offshore world, from cutting-edge technology to pressing issues. One hot topic was Net Zero and decarbonization. This refers to efforts to reduce carbon emissions to a net-zero balance, crucial for combating climate change and preserving our environment.

I believe the event served as an excellent platform for both job seekers and students seeking internships. The networking opportunities were abundant, and the chance to connect with potential employers was invaluable.

Let's not forget the food! The delicious Malaysian cuisine served throughout the event was a treat. From local delicacies to mouth-watering desserts, it showcased the richness of Malaysian culinary culture.

In conclusion, the Offshore Technology Conference was a gem of an event that should definitely happen again in the future. It brought together diverse minds, fostered learning, and celebrated the best of what the industry has to offer.

An Unprecedented Voyage on 'The Falkor (too)' Research Vessel

Monika Agrawal, IIT Delhi Student Branch Chapter Advisor

The OES Initiative program "Berth of Opportunity" started from 2022 matches OES members who are students or young professionals with available berths on the R/V Falkor (too), an oceanographic vessel owned and operated by Schmidt Ocean Institute. As reported here, arrangements have been made with the Institute through 2023. We look forward to receiving the applications this year (details are on another page of this issue).

As I stepped onto the deck of *Falkor (too)*, as a participant in the IEEE OES Berth of Opportunity program, I was immediately struck by the ship's sophistication. A marvel of modern engineering, *Falkor (too)* stood tall and proud, its sleek design and resolute stature evoked a profound sense of pride.

This illustrious research vessel of the Schmidt Ocean Institute, stands as a symbol of scientific exploration and innovation in oceanography. This state-of-the-art ship is equipped with

cutting-edge technology and advanced research equipment, empowering scientists and researchers to embark on transformative expeditions into the world's oceans.

The vessel is equipped with a Remotely Operated Vehicle (ROV), named "SuBastian," for exploring ocean depths and collecting precise samples from the bottom of sea. SuBastian can operate in water down to 4500m of depth. It is equipped with high resolution cameras to view the marine life closely. Conductivity, Temperature, and Depth (CTD) profilers offer insights into water properties at varying depths. Multi-beam Echo-sounders, Acoustic Doppler Current Profilers (ADCPs), and an Ultra-Short Base Line (USBL) position system further enhance marine research capabilities, making this a beacon of oceanic exploration. *Falkor (too)*'s missions encompass diverse topics, including marine biology, geology, oceanography, environmental science, and technology development.

Falkor (too)'s interior exuded an air of luxury, with spacious cabins offering breath-taking views of the vast sea. The ship's amenities surpassed all expectations, providing a comfortable home-away-from-home for the scientists, engineers, and artists aboard. Living on *Falkor (too)* was not just a scientific journey but also a culinary adventure. As a vegetarian, I was curious about how my dietary preferences would be accommodated on board. To my delight, the ship's talented chefs ensured that I had a diverse and delicious array of vegetarian options to savour.

The experiments conducted on *Falkor (too)* during my trip were an investigation into micro-plastics in the ocean. The team, comprised of young researchers from Denmark, was working very hard to collect samples day and night during the expedition, and *Falkor (too)* crew—science and engineers—were very happily supporting them in everything. Finding the levels of micro-plastic in the water is valuable research, raising awareness about this is urgent and why we need sustainable practices to protect our oceans.

Beyond the realm of science and engineering, *Falkor (too)* also hosted artists who joined the expedition to capture the essence of the voyage through their art. The fusion of art and science on-board was a unique and inspiring sight. Painters, photographers, and writers found inspiration in the vastness of



Science Team working on CTD (Photo by Alex, Schmidt Institute).

the ocean, the vibrant marine life, and the camaraderie among the crew. Their artistic interpretations of the voyage would serve as a testament to the power of creativity in enhancing our understanding of the natural world. Sustainable garment designer, clay artist, videographers on this journey were adding different flavours to the trip.

As my trip on *Falkor (too)* came to an end, I couldn't help but feel overwhelmed with gratitude and excitement. The experience had surpassed all my expectations, and I had gained invaluable insights into both the scientific and artistic aspects of oceanic exploration. The memory of my first journey on *Falkor (too)* would forever be etched in my heart, fuelling my passion for ocean research and inspiring me to encourage more students to embark on their own extraordinary journeys on this magnificent ship.

In fact the IEEE OES Berth of Opportunity program is a source of transformation and inspiration, fuelling the *Falkor (too)*'s quest to expand the horizons of knowledge. It's an open invitation, embracing remote, underfunded, and young researchers, reaching out to underserved communities. In the realm of academia and research, inequalities persist due to barriers like funds, location, and systems, limiting the potential of bright minds. The IEEE OES Berth opportunity shines as a beacon of hope, breaking down exclusivity and welcoming researchers from diverse backgrounds.

By connecting with underserved communities, IEEE-OES is not only democratizing access to knowledge but also enriching our collective intellectual landscape. It's a potential symbol of progress, forging new paths in research and nurturing a future where equality and advancement unite. Top of Form

I am really thankful for IEEE OES for sending me to this unconventional journey and *Falkor (too)* for hosting me for all these days. I hope I will come back here again with my team to test out my systems and algorithms on this unique research vessel soon!!



SuBastian the ROV (Photo by Sofia Schmidt Institute).



CTD in full action (Photo by Alex, Schmidt Institute).



Special Vegetarian Delicacy (Photo by author).



Status Updates (Photo by author).



Team on board. (Photo by Alex, Schmidt Institute).



Artist (ShanHua) on board. (Photo by Alex, Schmidt Institute).



Deck of Falkor (too) (Photo by Alex, Schmidt Institute).



Artist (PeiWen) on board. (Photo by Alex, Schmidt Institute).



Panama at night from Falkor (too) (Photo by Alex, Schmidt Institute).

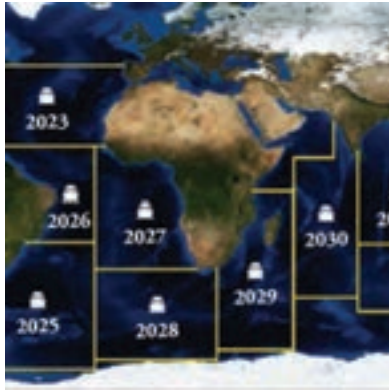

Program Summary

The Berth of Opportunity program matches OES members who are students or young professionals with available berths on the R/V Falkor (too), an oceanographic vessel owned and operated by Schmidt Ocean Institute.

Falkor (too) conducts ocean-related biology, chemistry, physics, geology, oceanography and/or marine technology research. Research cruises normally last between 10 and 30 days. Participants in the program will either support the Principal Investigators of the research cruise or conduct their own experiments in addition to supporting the PI's research program.

The purpose of this program is two-fold:

- (1) provide members who do not have access to sea trials with an opportunity to experience field research, learn valuable skills, and make life-long connections;
- (2) build and strengthen relationships between the IEEE OES community and the scientific community through Schmidt Ocean Institute's network.

Application Process

Interested candidates are requested to submit an application here:

<https://forms.gle/w2rbvv9x4CDTh2x19>

Travel costs associated with participating in a cruise will be paid by the IEEE-OES. These costs include airfare, accommodations, incidental and meal allowance, and ground transportation. On-cruise costs, such as accommodation and meals, are covered by SOI.

A tentative schedule for future expeditions will be available on the Cruise Website. Applicants should provide 1-3 preferred expeditions that they would like to join;

Berths can be made available during shorter transits between ports if candidates want to test technology or use the vessels underway systems;

All submitted applications will be reviewed by the IEEE-OES committee, SOI team, and PIs of the research cruises that the applicant selects;

Applicants will receive notification of acceptance of their application no later than one month before cruise departure.

Selection criteria include the applicant's research plan, career goals, academic qualifications, professional qualifications, creative innovation, and the relevance of their research interests with the research cruise.

Expectations

Participants are expected to follow the SOI operational procedures before and during the cruise, including its COVID policy, as well as safety training onboard the Falkor (too) on the day before the R/V sets sail;

Participants are expected to maintain good health before and during the cruise. If you experience COVID symptoms or any serious health conditions before the cruise, please contact the SOI and IEEE-OES to review if we need to reschedule;

If participants conduct their own experiments during the cruise, they are expected to share the data from these experiments as specified in the SOI agreement;

Participants are expected to obtain a receipt for all costs that they submit to the IEEE-OES for reimbursement after the cruise;

Before joining the expedition, participants are required to have completed Basic Training in Sea Survival Techniques or Personal Survival Techniques, as outlined in table A-VI/1-4 of the STCW Code.

Participants are expected to submit a short report of their experience for publication in Earthzine, the IEEE-OES on-line magazine and the IEEE-OES Beacon newsletter;

Participants are encouraged to present papers based on the research done during the expedition at an upcoming IEEE OCEANS conference.



IEEE OES PUBLICATIONS

IEEE JOURNAL OF OCEANIC ENGINEERING

A quarterly journal published by the IEEE Oceanic Engineering Society.

<https://ieeooes.org/publications/ieee-journal-of-oceanic-engineering/>



OES BEACON NEWSLETTER

Provides articles on the latest society conferences, activities, members, etc., along with promotional information on upcoming OES events.

<https://ieeooes.org/publications/oes-beacon/introduction-to-the-oes-beacon-newsletter/>



IEEE EARTHZINE

Provides up-to-date information on science, technology, Earth/Ocean observation and information utilization and those participating and contributing to it's advancement.

<https://earthzine.org/>



IEEE Oceanic Engineering Society

ATTENTION OES STUDENTS



INTERNATIONAL STUDENT POSTER COMPETITION FREE TRAVEL TO A CONFERENCE PRIZE MONEY WWW.IEEEOES.ORG

IF YOU'RE AN OES STUDENT MEMBER, DON'T MISS OUT ON
YOUR CHANCES TO ENTER THE STUDENT POSTER COMPETITION

HAVE YOU COMPLETED SOME EXCELLENT RESEARCH? BE SURE TO ENTER THE OES STUDENT POSTER COMPETITION. UP TO 25 INTERNATIONAL STUDENTS ARE CHOSEN TWICE A YEAR TO TRAVEL, ALL EXPENSES PAID, TO THE NEXT OCEANS CONFERENCE TO PRESENT THEIR RESEARCH IN THE POSTER SESSION. THE THREE TOP POSTERS RECEIVE **\$3,000, \$2,000 AND \$1,000** FOR 1ST, 2ND AND 3RD PLACE.

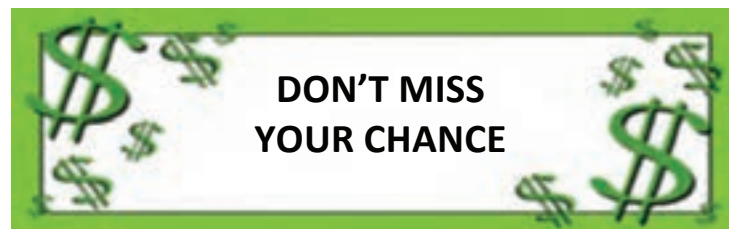

IEEE OCEANIC ENGINEERING SOCIETY EX-OFFICIO ADMINISTRATIVE COMMITTEE

Co-Editors-in-Chief, OES BEACON HARUMI SUGIMATSU University of Tokyo ROBERT WERNLI First Centurion Enterprises	Women in Engineering FARHEEN FAUZIYA	CHAPTER CHAIRS	VANCOUVER Jacqueline Nichols	REGION 10, ASIA & PACIFIC
Earthzine Editor-in Chief HARI VISHNU	Young Professional ROBERTO PETROCCIA	REGION 1-6, USA	VICTORIA Del Dakin	AUSTRALIA Mohan Jacob
Social Media VACANT	Technology Committee Coordinator M. A. ATMANAND	PROVIDENCE Gopu Potty	REGION 8, EUROPE, MIDDLE EAST & AFRICA	DELHI Arun Kumar
Webmaster BHARATH KALYAN	Joint Conference Committee (JCC) BRIAN HORSBURGH	HOUSTON In Chul Jang	FRANCE Philippe Courmontagne	HONG KONG Paul Hodgson
Student Activities SULEMAN MAZHAR	Awards, Nominations JERRY C. CARROLL	SAN DIEGO Jack Gallegos	ITALY Maurizio Migliaccio	INDONESIA Marina Frederik
Membership Development ELIZABETH CREED	Chapter Coordinator MAURIZIO MIGLIACCIO	SEATTLE Gerald (Skip) Denny	NORWAY John Potter	JAPAN Masanao Shinohara
Fellow Evaluating Committee ROSA ZHENG		HAWAII Mark Rognstad	PORTUGAL Nuno Cruz	KOREA Son-Cheol Yu
		REGION 7, CANADA	SPAIN Joaquin del Rio Fernandez	MADRAS V Sriram
		CANADIAN ATLANTIC Mae L. Seto	RUSSIA Igor Shirokov	MALAYSIA Zool H Ismail
		NEWFOUNDLAND & LABRADOR Weimin Huang	TUNISIA Habib Kammoun	NEW SOUTH WALES Ollencio D' Souza
		OTTAWA Zied Bouida	UKRI (REGION 8) Radhakrishna Prabhu	SHANGHAI Lian Lian
		QUEBEC Saeid Homayouni	REGION 9, SOUTH AMERICA	SINGAPORE Bharath Kalyan
		TORONTO AliReza Sadeghian	ARGENTINA Gerardo Acosta	TAIWAN Forng C. Chiu

TECHNOLOGY COMMITTEE CHAIRS

AUTONOMOUS MARITIME SYSTEMS (AMS) BHARATH KALYAN BILL KIRKWOOD	DATA ANALYTICS, INTEGRATION AND MODELING GOPU POTTY ANANYA SEN GUPTA	OCEAN REMOTE SENSING FERDINANDO NUNZIATA PAOLO DE MATTHAEIS	SUBSEA OPTICS AND VISION HAIYONG ZHENG JOHN WATSON	UNDERWATER COMMUNICATION, NAVIGATION, AND POSITIONING MILICA STOJANAVIC MANDAR CHITRE
CURRENT, WAVE AND TURBULENCE MEASUREMENT AND APPLICATIONS WEIMIN HUANG	OCEAN OBSERVATION AND ENVIRONMENTAL SUSTAIN- ABILITY RENÉ GARELLO R. VENKATESAN	OCEAN SUSTAINABLE ENERGY SYSTEMS BILL WILSON	UNDERWATER ACOUSTICS SULEMAN MAZHAR MEHDI RAHMATI XUEBO ZHANG	
		POLAR OCEANS ANDREAS MAROUCHOS XIONG (BILL) YU		

JOURNAL ASSOCIATE EDITORS

Saeed Anwar	Brendan Englot	Nina Mahmoudian	Loannis Rekleitis	Karl von Ellenrieder
Filippo Arrichiello	Fausto Ferreira	Toshihiro Maki	Peng Ren	Yu Wang
M.A. Atmanand	Kenneth Foote	Giulia De Masi	Alessandro Ridolfi	Huang Weimin
David Barclay	Eric Gill	Eliza Michaloupoulou	Torstein Sæbø	Wen Xu
Edmund F. Brekke	Joao Gomes	Andrey Morozov	Yan Song	Fumin Zhang
Li Chongyi	Chunle Guo	Andrea Munafò	Joao de Sousa	Peng Zhang
Nicholas Chotiros	Merrick Haller	Tracianne Neilsen	Milica Stojanovic	Haiyong Zheng
Brandon Cochenour	Michael Hayes	Barbara Nicolas	Ken Takagi	Rosa Zheng
Runmin Cong	Wei He	Costas Pelekanakis	Yufei Tang	Yifan Zhou
Riccardo Costanzi	Alan Hunter	Vincenzo Piscopo	Blair Thornton	
Nuno Cruz	Guoyuan Li	John Potter	Harris Tsimenidis	
Roe Diamant	Hua Li	Gopu Potty	Andrea Trucco	

STUDENT BRANCH CHAPTER ADVISORS AND CHAIRS

Escuela Superior Politecnica Del Litoral Advisor: Rafael Gonzalez Chair: Yuneski Solorzano	Panimalar Institute of Technology—CHENNAI Advisor: Arun M Chair: Vacant	University of Florence Advisor: Alessandro Ridolfi Chair: Alessandro Bucci
Escuela Tecnologica Inst Tecnico Central Advisor: Jose Lugo Chair: Jeisson Giraldo Tique	Pontificia Universidad Catolica de Chile Advisor: Giancarlo Troni Chair: Javiera Fuentes	University of Haifa Advisor: Itzik Klein Chair: Nadav Cohen
Indian Institute of Technology—Chennai Advisor: M. A. Atmanand Chair: Sridhar Krishnamoorthy	Shanghai Jiao Tong University Advisor: Zheng Zeng Chair: Yufei Jin	University of Limerick Advisor: Gerard Dooly Chair: Ben Bartlett, Matheus Santos
Indian Inst of Tech-Delhi, OE22 Advisor: Dr. Monika Aggarwal Chair: Puja Dube	Southwest Petroleum University Advisor: Suleman Mazhar Chair: Qingyuan Pu	University of Southern Mississippi Advisor: Kemal Cambazoglu Chair: Vacant
KMEA Engineering College-Aluva Advisor: Sunil Paul Chair: Anfal Hisham Thangal P	Sri Sai Ram Engineering College Advisor: Sivaramakrishnan S Co-chairs: Pradeepa R, Agritha vijay	University of Zagreb Advisor: Nikola Miskovic Chair: Igor Kvasic
National Agronomic Institute of Tunisia Advisor: DAALLOUL Olfa Chair: Chatti Nour	Strathclyde University Advisor: Andrea Coraddu Chair: Katarzyna Patryniak	Western Washington Univ Advisor: John Lund Chair: James Kintzele
National Engineering School of Sfax (ENIS) Advisor: Habib Kammoun Chair: Abir Abid	Universidad Peruana de Ciencias Aplicadas Advisor: Nikolai Vincens Chair: Oscar Hurtado Talavera	

OCEANS

CONFERENCE & EXPOSITION

2 0 2 4

HALIFAX

September 23-26, 2024

Join experts, researchers, and industry
leaders from around the world shaping
the future of tomorrow's ocean



FIND OUT MORE AT

halifax24.oceansconference.org